

Integrated Motor-Pump Units

GMP-Type

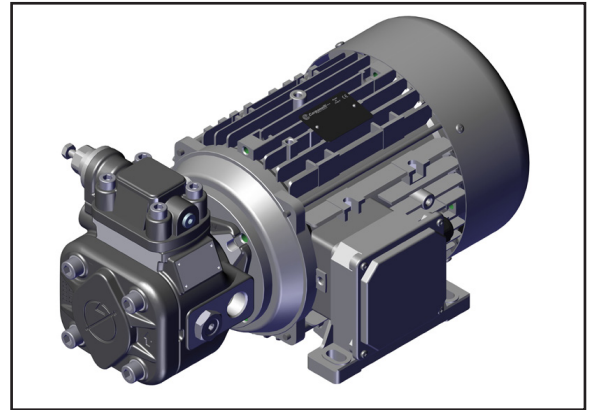

Key Features:

Direct coupling between motor and pump

Rotation: Right (viewed from shaft end)

Electric motor mounting type: special B3-B14 (IEC 34-7)

Rated Voltage: 230/400 V +/-10% at 50 Hz - 266/460 V +/-10% at 60 Hz

Efficiency Class: IE3

Available power: from 0.75kW (1HP) to 7.5kW (10 HP)

Series/Name	Rated Displacement (cm ³ /r)	Maximum Flow Capacity at 1450 rpm (L/min)	Maximum Pressure (bar)
GMP-16	16	23	250
GMP-20	20	29	250
GMP-25	25	36	250
GMP-32	32	46	250

CONTENTS

GENERAL DESCRIPTION D-3

ORDERING CODE D-3

PUMP TECHNICAL DATA D-4

ELECTRIC MOTOR TECHNICAL DATA D-5

OVERALL DIMENSIONS D-6

INSTRUCTIONS FOR INSTALLATION AND USE D-7

ASSEMBLY D-8

WARNING

All Berarma pumps have been carefully checked during manufacture and subjected to stringent testing cycles before shipment. To achieve optimum performance, avoid problems, and maintain the warranty, the installation instructions enclosed with each pump sold must be strictly observed.

NOTES

Before selection and/or use of any Berarma product, it is important that the purchaser carefully analyses all aspects of its application and reviews the information in the current Berarma Technical-Sales catalogues. Due to the many different operating conditions and applications for Berarma products, the purchaser, through their own analysis and testing, is solely responsible for making the final selection of the products and assuring that all performance and safety requirements are met.

Berarma S.r.l. accepts no responsibility for any editing mistakes in this catalogue.

Berarma S.r.l. reserves the right to modify the products and data contained in this catalogue at any time and without prior notice.

GENERAL DESCRIPTION

In its constant search for solutions that cut costs, dimensions and simplify the application of its products, Berarma has developed Integrated Motor Pump Units, known as GMPs, with direct drive. The direct coupling system allows all parts between the pump and motor to be eliminated (couplings, bell-housing, supports etc.) and ensures perfect concentricity between the two shafts, avoiding dangerous not-alignment which can cause abnormal wear.

GMPs are produced using Berarma SIZE 05 and SIZE 1 pumps (displacement up to 32 cm³/r, a maximum working pressure up to 250 bar) and with asynchronous three-phase electric motors with special mounting flange (rated power 0.75 - 7.5 kW).

The GMP is easy and quick to install and can be mounted directly on the powerpack (anti-vibration mounts are recommended).

ORDERING CODE

Series/ Name	Displacement	Pump type	Pressure setting	Motor type
GMP				

Code	Size	Displacement (cm ³ /r)
16	05	16
20	1	20
25	1	25
32	1	32

Code	Pressure Compensator
PLP	Mechanical
PHP	Hydraulic

Code	Pressure setting
H	See Page 4
L	

Code	Motor type
MRE	See Page 5

Ordering code example:

- GMP 25 PLP H MRE 112 a4

NOTE: For further information and/or special operating conditions of the pumps and electric motors, please consult the relevant Berarma catalogues or contact Berarma Technical Service.

PUMP TECHNICAL DATA

Pump type - Nominal size	PLP 05	PHP 05	PLP 1	PHP 1
Geometric displacement according to UNI-ISO 3662 (cm ³ /r)	16	16	20 - 25 - 32	20 - 25 - 32
Actual displacement (cm ³ /r)	17.9	17.9	24.2 - 29.4 - 34.5	24.2 - 29.4 - 34.5
Due to manufacturing tolerances, the value can vary by approx. ± 3%				
Maximum working pressure (bar)	120	250	100	250
Pressure peaks exceeding 30% of the maximum operating pressure must be eliminated by adopting the appropriate measures				
Control pressure setting (bar)	H - 20/120	H - 20/250	L - 15/50 H - 30/100	H - 20/250
Mounting flange and port connections	4-hole flange (UNI-ISO 3019/2) - GAS-BSP threads (UNI-ISO 228/1)			
Permitted maximum drain port pressure (bar)	1			
Inlet pressure (bar)	0.8 - 1.5 absolute			
Speed range (r/min)	800 - 1600			
Rotation direction (viewed from shaft end)	R - Right			
Loads on drive shaft	NO RADIAL OR AXIAL LOADS ALLOWED			
Maximum torque on primary shaft (Nm)	110	130	250	250
Hydraulic fluid	HM hydraulic oil according to ISO 6743/4; HLP hydraulic oil according to DIN 51524/2; for other fluids contact Berarma Technical-Sales Service			
Viscosity range (cSt, mm ² /s)	22 - 68 at operating temperature			
Starting viscosity under full flow conditions (cSt, mm ² /s)	400 max			
Viscosity index according to ISO 2909	100 min			
Inlet fluid temperature range (°C)	+15 / +60- pay attention to viscosity range			
Maximum acceptable fluid contamination level	20/18/15 according to ISO 4406/99, CLASS 9 according to NAS 1638			
Recommended fluid contamination level for a longer pump working life	18/16/13 according to ISO 4406/99, CLASS 7 according to NAS 1638			

ELECTRIC MOTOR TECHNICAL DATA

The motors described in this catalogue are built according to international standards. Each dimension is calculated with reference to the tables in standard IEC 72-1. The power output for each size at 1500 - 1000 r/min has been established by UNEL/IEC documents, which define the values.

Asynchronous three-phase motors are closed, externally ventilated, with cage rotor and dynamically balanced.

Mounting type	special B3 - B14 (IEC 34-7)
Rated voltage	230/400V ±10% at 50Hz 266/460V ±10% at 60Hz
Efficiency class	IE3
Insulation class	F (IEC 34-1)
Degree of protection	IP 55 (EN 60529)
CE mark	European Community Directives 2014/25/EC & 2014/30/EC
Duty service	S1 (IEC 34-1)
Ventilation	Bidirectional fan with radial blades made of plastic to resist high temperatures. Fan housing is made of sheet metal
Frame, flanges and shields	Die-casting aluminium alloy Without coating
Terminal box position	Right (viewed from shaft end) Left or top position on request
Options	Thermal protection against peak loads Protection against peak currents CSA-C/US mark Electric motors with different voltage/frequency ATEX Certification

4 poles- 1500 r/min - 50Hz

type	power kW (HP)	rpm	η %	current A (400 v)	power factor FI	rated torque Cn Nm	torque ratio Cs/Cn	torque ratio As/An
MRE80 a	0.75 (1.0)	1430	82.5	1.8	0.76	5	3.1	6.2
MRE80 b	1.1 (1.5)	1420	84.1	2.4	0.82	7.4	3.5	6.2
MRE90 La	1.1 (1.5)	1430	84.3	2.5	0.77	7.3	4.1	7.5
MRE90 Lb	1.5 (2.0)	1430	85.3	3.5	0.74	10	4.3	7.5
MRE100	2.2 (3.0)	1440	86.7	5	0.75	14.6	3.3	7.8
MRE112 a	3.0 (4.0)	1460	87.9	6.5	0.76	19.5	4.7	10.8
MRE112 b	4.0 (5.5)	1440	88.6	8.2	0.8	26	3.6	7.8
MRE132 La	5.5 (7.5)	1460	90	11.3	0.79	36.1	4	8.5
MRE132 Lb	7.5 (10.0)	1450	90.4	14.9	0.81	49.3	3.8	8

The performances indicated refer to the following ambient conditions:

- altitude below 1000 m above sea level
- ambient temperature +5°C / +40°C (Pn <0.6 kW)
- ambient temperature -15° / +40°C (Pn >0.6 kW)
- relative humidity 30% / 95% (without condensation)

OVERALL DIMENSIONS

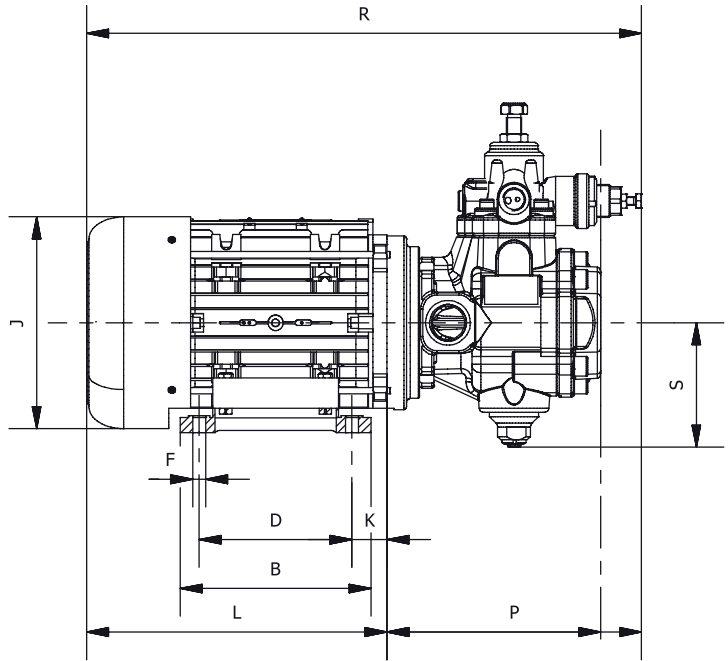
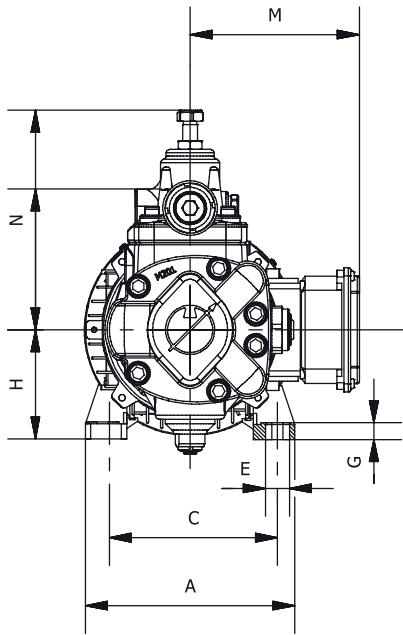

For complete pump dimensions, please refer to the corresponding technical catalogue.

Pump	Motor	A	B	C	D	E	F	G	H	J	K	L	M	N	P	R	S
PLP 05	MRE80	154	125	125	100	17.5	9.5	11	80	156	52	237	141	164	107	344	82
PHP 05														131	145	382	98
PLP 05	MRE90	174	155	140	125	17.5	9.5	13	90	176	56	275	146	164	107	382	82
PHP 05														131	145	420	98
PLP 1														201	166	441	114
PHP 1														132	203	478	114
PLP 05	MRE100	192	175	160	140	21.2	11.2	15	100	194	62	304	157	164	107	411	82
PHP 05														131	145	449	98
PLP 1														201	166	470	114
PHP 1														132	203	507	114
PLP 05	MRE112	226	175	190	140	21.2	11.2	15	112	220	70	325	169	164	107	432	82
PHP 05														131	145	470	98
PLP 1														201	166	491	114
PHP 1														132	203	528	114
PLP 05	MRE132	260	218	216	178	21.2	11.2	17.5	132	256	88	410	195	164	107	517	82
PHP 05														131	145	555	98
PLP 1														201	166	576	114
PHP 1														132	203	613	114



INSTRUCTIONS FOR INSTALLATION AND USE

- 1) GMP integrated Motor-Pump Units must be mounted on a horizontal axis (see figure).
When the pump is installed above the tank oil level, pay attention to the inlet pressure (page 4).
The minimum section of the inlet pipe must be equal to the section of the thread of the pump inlet port. The inlet pipes should be as short as possible, with a small number of bends and without internal section changes.
- 2) All return and drain pipes must be positioned so that the oil cannot be sucked back directly by the pump (see figure).
The oil tank must be suitably sized in order to exchange the thermal power generated by the various system components and to provide a low recycle rate.
To ensure the maximum pump working life, the inlet oil temperature must never be above 60°C. In systems where the pump runs for a long time under zero flow setting conditions, the installation of a heat exchanger in the drain line is recommended.
The pressure on the drain port must never exceed the specified value (page 4).

The drain pipe must always be independent from the other return lines, connected directly to the tank, and extended sufficiently inside the tank so as to be below the minimum oil level to avoid generating foam. Moreover, the drain pipe must be free of restrictions and as far as possible from the inlet pipe.

- 3) No induced RADIAL or AXIAL LOADS are allowed on the pump shaft.
- 4) During initial installation, the pump must be run under maximum flow conditions (P connected to T), with the oil flowing directly into the tank, in order to induce air bleeding. This phase must run for several minutes.
Pump priming (delivery of oil to the outlet) must occur within a few seconds, otherwise the pump must be turned off and the operation repeated. Subsequent start-ups under zero flow setting conditions are admissible only with pressure not exceeding 30 bar, and with the system and pump completely filled with oil.
During the initial and subsequent starting operations, the difference between the oil temperature and the ambient temperature (body pump temperature) must not exceed 20°C.

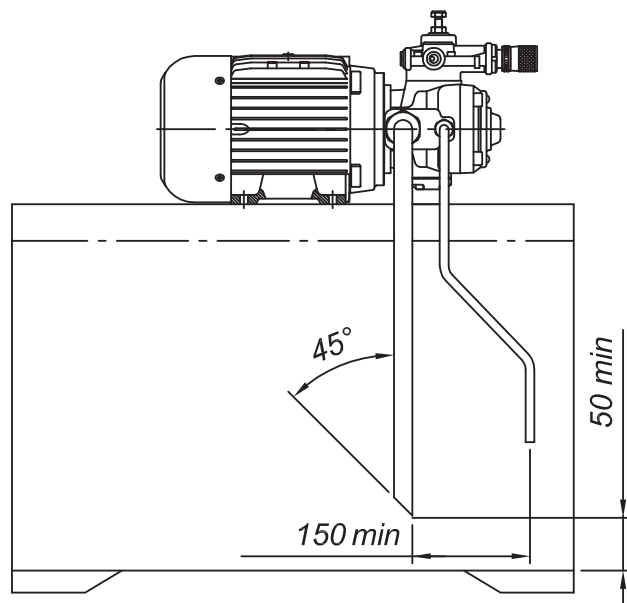
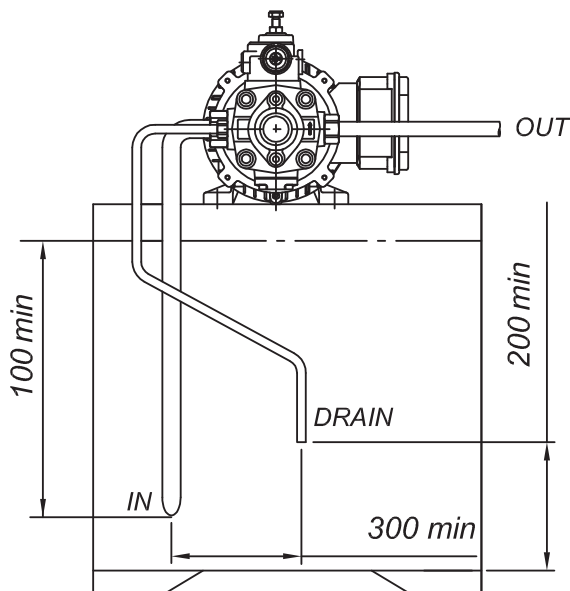

ASSEMBLY

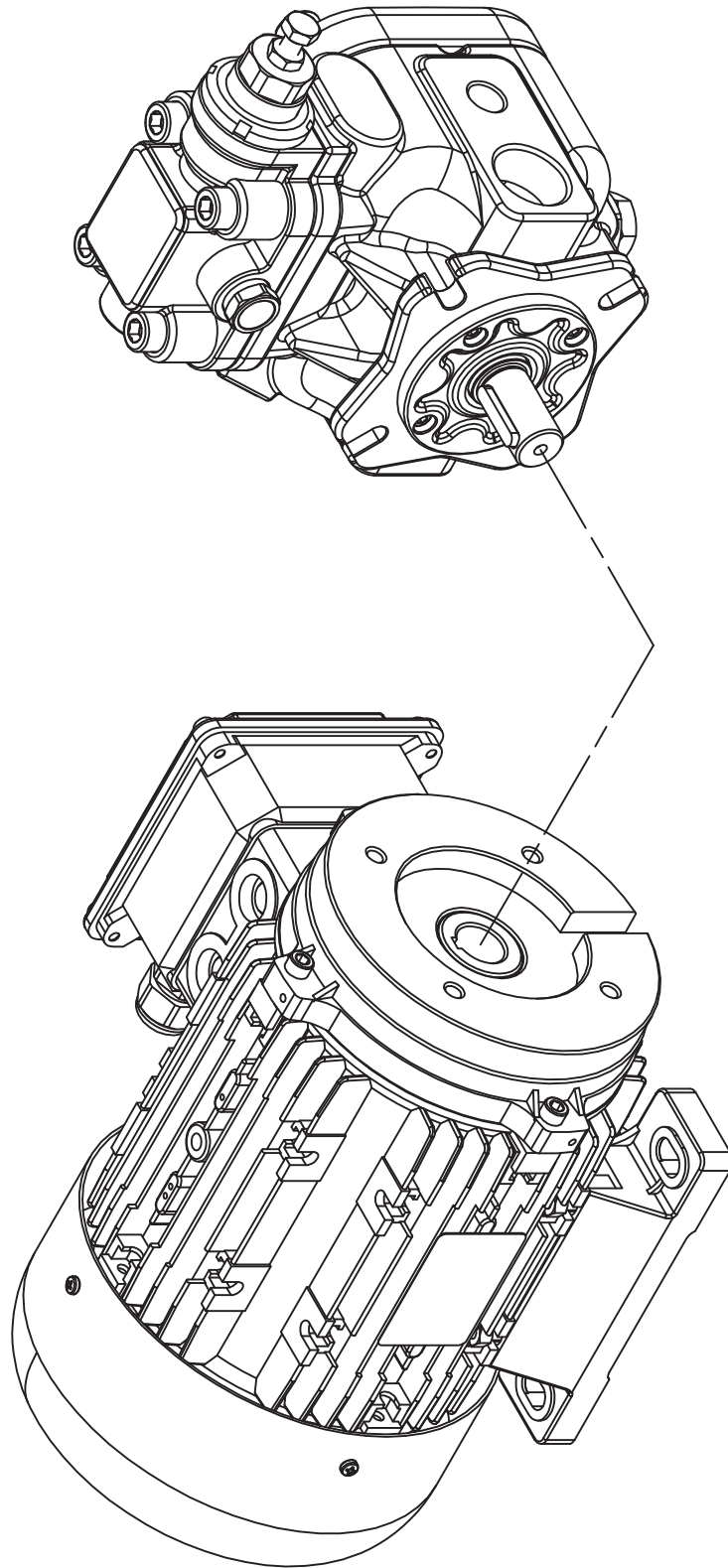

Berarma S.r.l. accepts no responsibility for any editing mistakes in this catalogue.
Berarma S.r.l. reserves the right to modify these data without prior notice.