

XL - VERTICAL LEVEL GAUGES WITH METAL CASING

XLT - VERTICAL LEVEL GAUGES WITH METAL CASING WITH THERMOMETER

XLT/PLAST - VERTICAL LEVEL GAUGES WITH PLASTIC CASING



XL/05

External protection made from painted steel



XL/05-VL



XL/05T-PLAST

External protection made from PA66 30% fiberglass

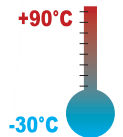

-Vertical level gauges made from transparent polyamide which provides good mechanical resistance to shocks, hydraulic fluids, synthetic and mineral oils, diesel and some unleaded fuel.

-Avoid contact with alcohol based solutions and antifreeze liquids, especially at high temperatures.

-Max working temperature suggested **90°C/194°F** (test made up **1 bar /14,5 PSI** of pressure).

-External protection is provided by a steel casing with black painted finish: also available in version VL with side openings to allow visibility from both sides.

These level gauges are used in oil and fuel tanks of many types, due to their ability to remain clear in the majority of conditions; the transparent body retains its transparency under most environmental conditions.

-The body of the level gauges is made by ultrasonically welding two halves together to ensure a leak free seal

around the body. Inside is fitted a white screen with minimum and maximum level indication. External seal is guaranteed by O-Rings and flat rubber washers NBR 80 Shore for each fixing bolt.

-The mounting of the level gauge can be made externally by providing 2 threaded holes M10 or M12 on 76-127 mm centre distance, tolerance $\pm 0,2\text{mm}$. Alternatively they can be secured internally through 2 plain holes $\varnothing 10,2\text{ mm}$ or $\varnothing 12,2\text{ mm}$ using the flanged nuts provided. Maximum tightening suggested **3 Nm**.

-Model XLT-05 is equipped with an inside thermometer scaled in degree Celsius 0-100° C and Fahrenheit 50-200 °F (Model XL/03T 0-80°C/50-175°F).

-In case of use under pressure and/or temperature conditions other than those indicated or with specific fluids and/or chemical agents, contact the technical service Miselli srl.

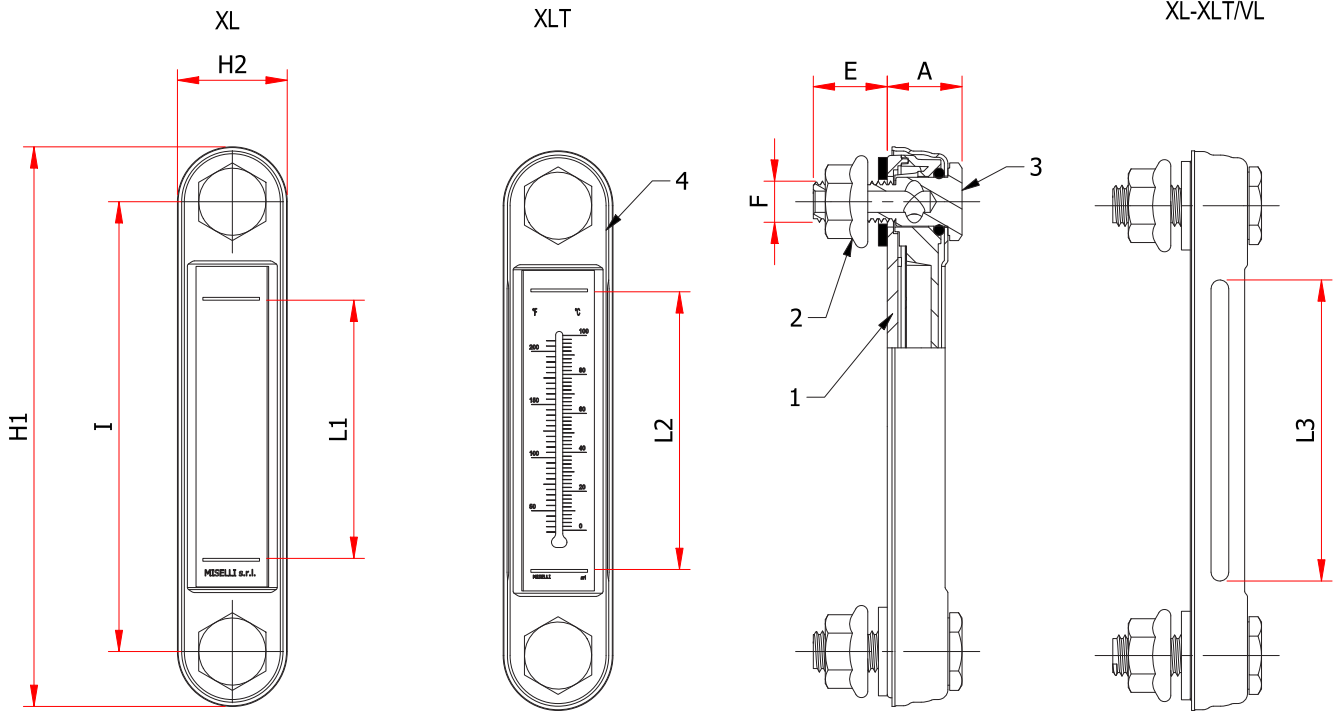

- 1 = Transparent main body
- 2 = Flanged hex nut
- 3 = Hollow bolt
- 4 = Metal shell

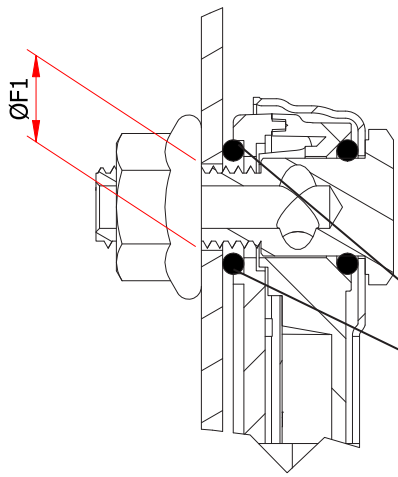

Special Executions

- **Model XL-T/CX** made from special resin resistant to fluid containing alcohol and anti-freeze liquids.
- **Model XL-T/RB** with floating red ball to improve the visibility of the fluid level of light colored liquids.
- **Model XL-T/PLAST:** external casing made from polyamide 66 30% fiberglass reinforced; available model with stainless steel nuts and bolts AISI 304 suitable for applications in corrosive environments such as marine.
- **Model XL-T/OR** back seal provided through O-Ring in NBR synthetic rubber.
- **Model XL-T/V** with O-Ring seal made from FKM VITON®.

Code	I	H1	H2	F	E	A	L1	L2	ØF1	L3	Weight gr
XL/03	76	107	31	M10-M12	17,5	24,5	37		10,2-12,2	34	135
XL/03T	76	107	31	M10-M12	17,5	24,5		37	10,2-12,2	34	135
XL/05	127	158	31	M10-M12	17,5	24,5	73		10,2-12,2	85	187
XL/05T	127	158	31	M10-M12	17,5	24,5		78	10,2-12,2	85	187