

LEG SERIES

DIMENSIONS

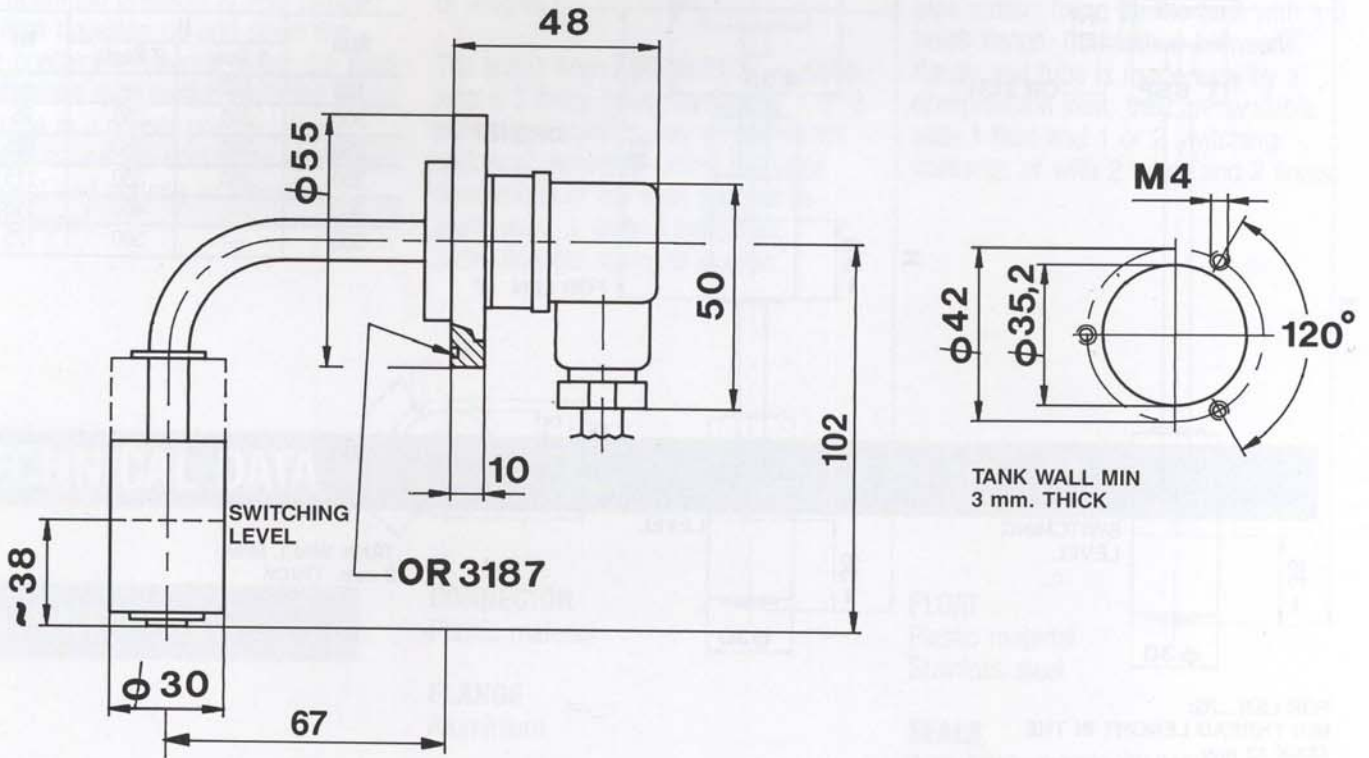

ORDERING INFORMATION

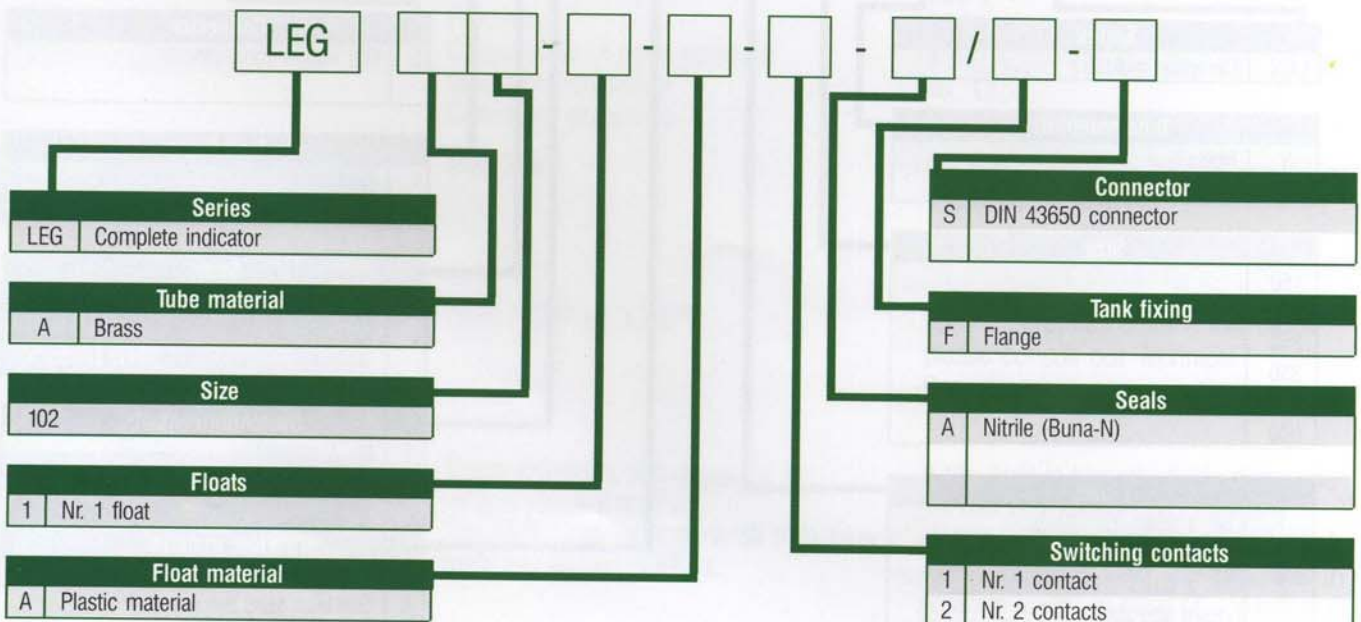

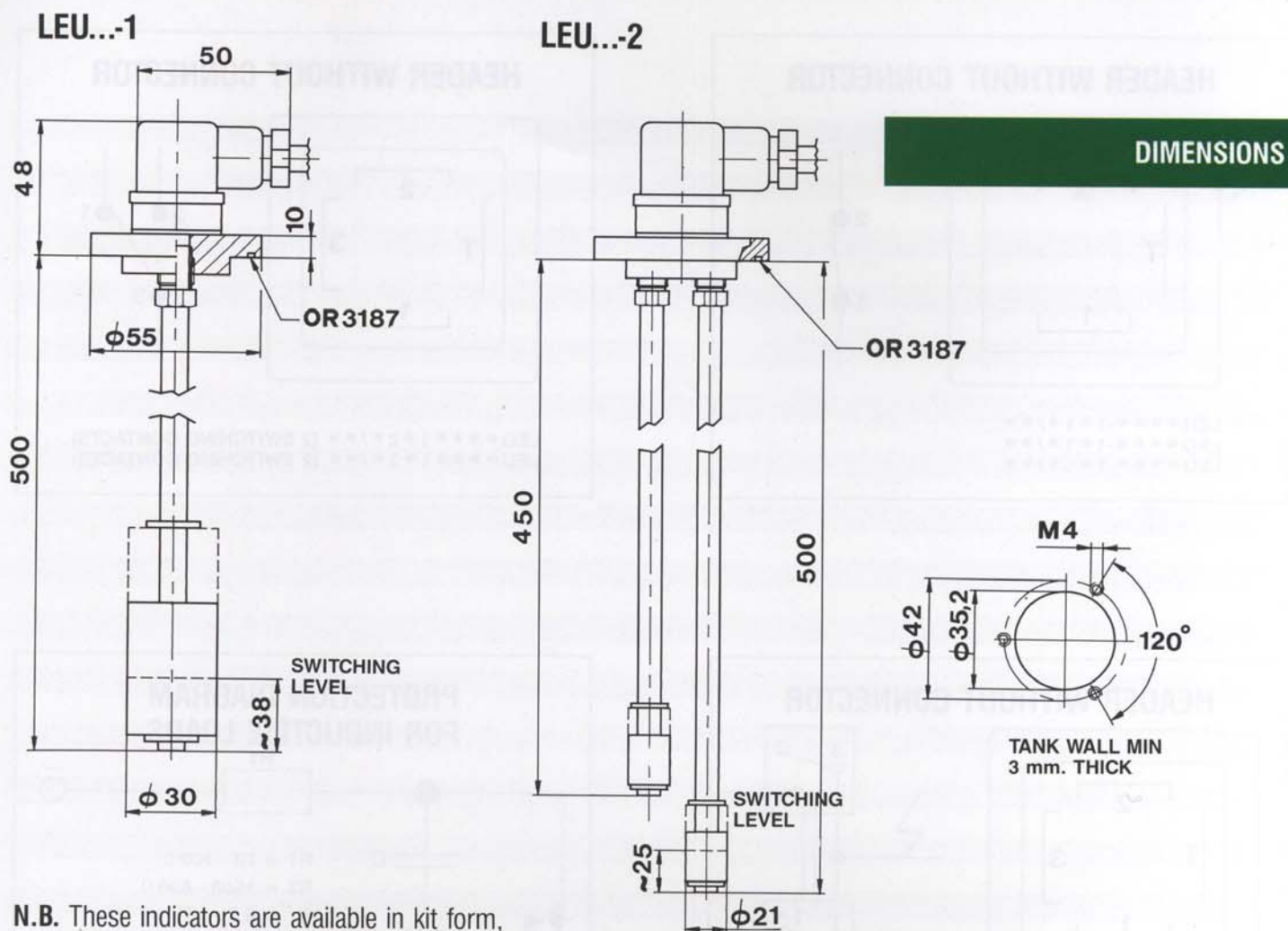

N.B. These indicators are available in kit form, thus length can be adjusted by customer.

ORDERING INFORMATION

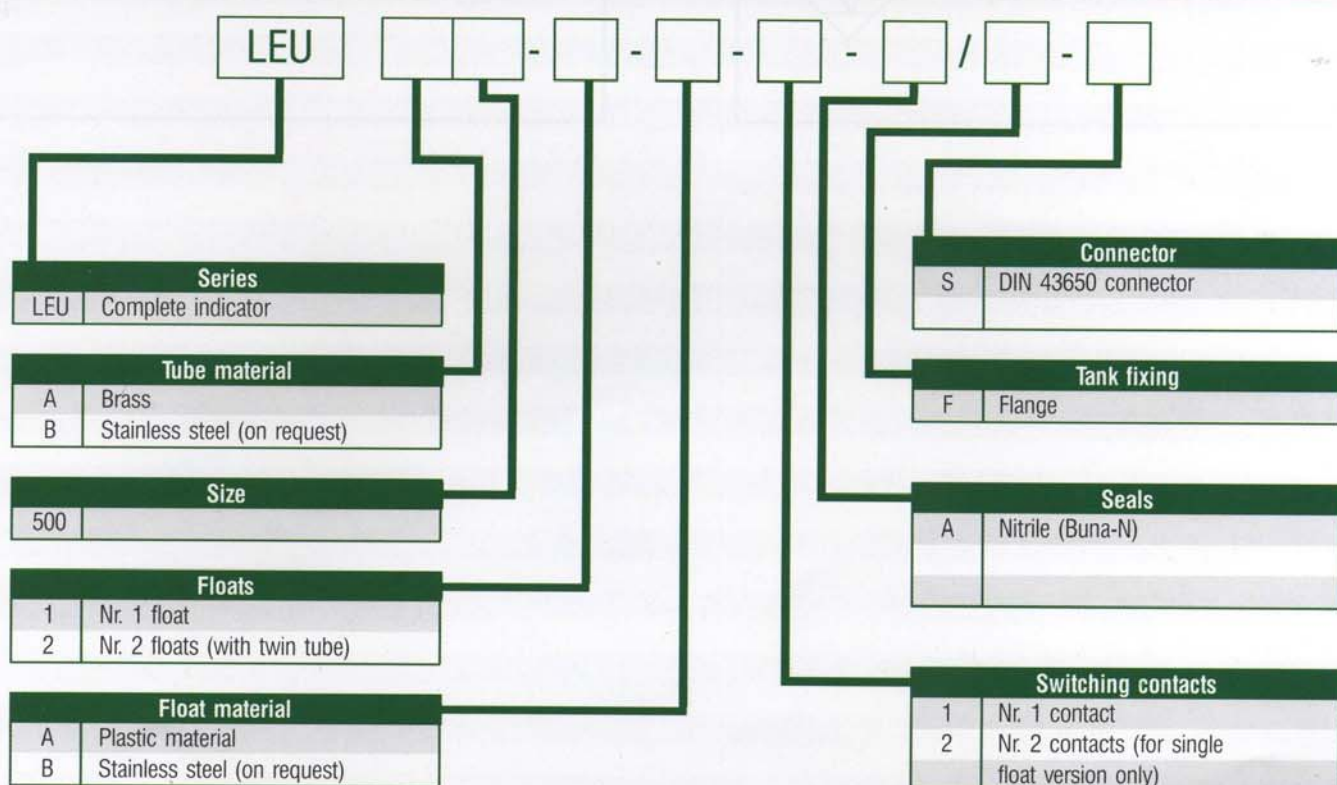

HEADER WITHOUT CONNECTOR

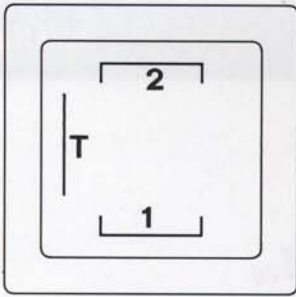

LEN *****-1*1**/*
 LEG *****-1*1**/*
 LEU *****-1*1**/*

HEADER WITHOUT CONNECTOR

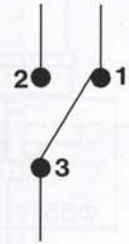
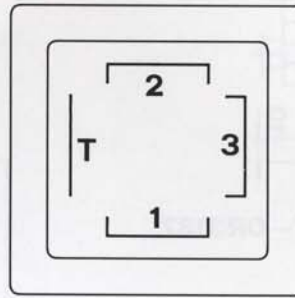

LEG *****1*2**/* (2 SWITCHING CONTACTS)
 LEU *****1*2**/* (2 SWITCHING CONTACTS)

HEADER WITHOUT CONNECTOR

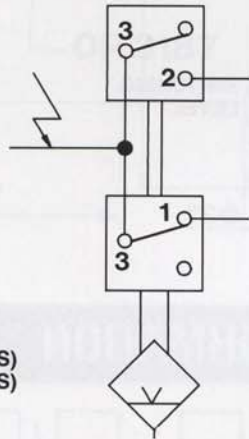
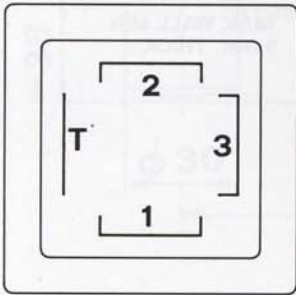

LEN *****2*1**/* (2 FLOATS)
 LEU *****2*1**/* (2 FLOATS)

PROTECTION DIAGRAM FOR INDUCTIVE LOADS

