

FMP 039 series

Maximum working pressure up to 11 MPa (110 bar) - Flow rate up to 80 l/min



FMP 039 GENERAL INFORMATION

Description

Technical data

High Pressure filters

In-line

Maximum working pressure up to 11 MPa (110 bar)
Flow rate up to 80 l/min

FMP039 is a range of versatile medium pressure filter for transmission, protection of sensitive components in medium pressure hydraulic systems and filtration of the coolant into the machine tools. They are directly connected to the lines of the system through the hydraulic fittings.

Available features:

- 1/2" female threaded connections, for a maximum flow rate of 80 l/min
- Fine filtration rating, to get a good cleanliness level into the system
- Bypass valve, to relieve excessive pressure drop across the filter media
- Low collapse filter element "N", for use with filters provided with bypass valve
- Visual, electrical and electronic differential clogging indicators

Common applications:

Delivery lines, in any medium pressure industrial equipment or mobile machines

Filter housing materials

- Head: Anodized aluminium
- Housing: Anodized aluminium
- Bypass valve: Steel

Pressure

- Test pressure: 17 MPa (170 bar)
- Burst pressure: 33 MPa (330 bar)
- Pulse pressure fatigue test: 1 000 000 cycles with pressure from 0 to 11 MPa (110 bar)

Bypass valve

- Opening pressure 600 kPa (6 bar) $\pm 10\%$
- Other opening pressures on request.

Δp element type

- Microfibre filter elements - series N: 20 bar
- Wire mesh filter elements - series N: 20 bar
- Fluid flow through the filter element from OUT to IN.

Seals

- Standard NBR series A
- Optional FPM series V

Temperature

From -25 °C to +110 °C

Connections

In-line Inlet/Outlet

Note

FMP 039 filters are provided for vertical mounting



Weights [kg] and volumes [dm³]

Filter series	Weights [kg]				Volumes [dm ³]			
	Length	2	3	4	Length	2	3	4
FMP 039		0.60	0.70	0.80		0.19	0.26	0.34

Executions

Execution 1:
without indicator connection

Execution 6:
double indicator connection (A - B)

A: Closure cap with standard T2 steel. The position of the cap is reversible.

B: Standard closure cap with plastic thread protection. If necessary, a second T2 plug is available, see ordering information.

Special connections on request

Filter series	Length	Filter element design - N Series					
		A03	A06	A10	A16	A25	M25
FMP 039	2	20	26	45	52	61	97
	3	35	39	56	64	76	98
	4	44	48	66	71	82	92

Maximum flow rate for a complete pressure filter with a pressure drop $\Delta p = 1.5$ bar.

The reference fluid has a kinematic viscosity of 30 mm²/s (cSt) and a density of 0.86 kg/dm³.

For different pressure drop or fluid viscosity we recommend to use our selection software available on www.mpfiltri.com.

You can also calculate the right size using the formulas present on the FILTER SIZING paragraph at the beginning of the full catalogue or at the beginning of the filter family brochure. Please, contact our Sales Department for further additional information.

Hydraulic symbols

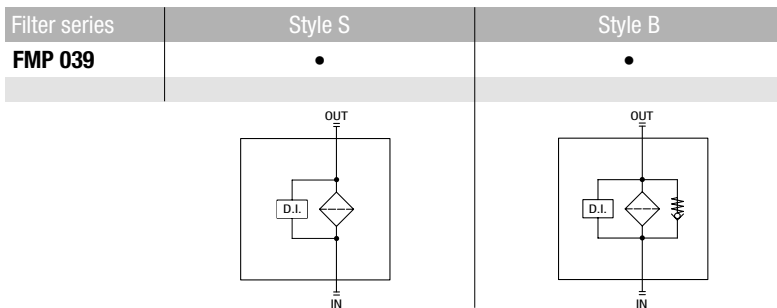

Pressure drop

Filter housings Δp pressure drop

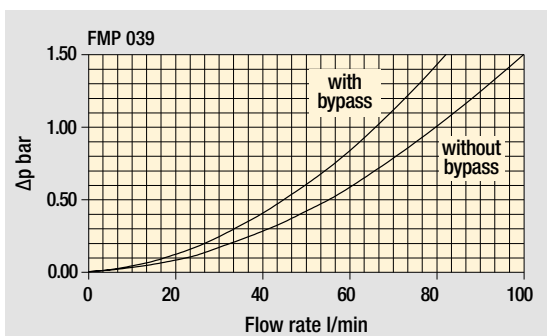

Bypass valve pressure drop

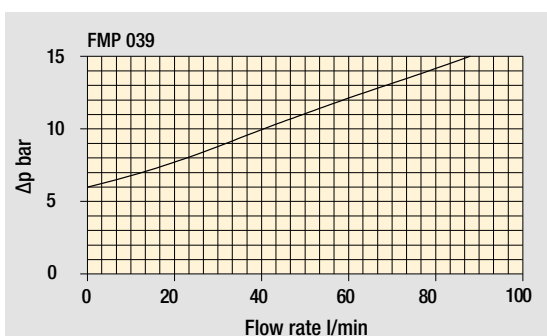

The curves are plotted using mineral oil with density of 0.86 kg/dm³ in compliance with ISO 3968. Δp varies proportionally with density.

FMP 039

Designation & Ordering code

COMPLETE FILTER

Series and size	Configuration example: FMP039 3 B A B 6 A03 N P01															
FMP039																
Length	2 3 4															
Valves	S Without bypass B 6 bar															
Seals	A NBR V FPM															
Connections	A G 1/2" B 1/2" NPT C SAE 8 - 3/4" - 16 UNF															
Connection for differential indicator	1 Without 6 With two connections on both sides															
Filtration rating (filter media)	<table border="0"> <tr> <td>A03 Inorganic microfiber 3 µm</td> <td>A16 Inorganic microfiber 16 µm</td> </tr> <tr> <td>A06 Inorganic microfiber 6 µm</td> <td>A25 Inorganic microfiber 25 µm</td> </tr> <tr> <td>A10 Inorganic microfiber 10 µm</td> <td>M25 Wire mesh 25 µm</td> </tr> </table>										A03 Inorganic microfiber 3 µm	A16 Inorganic microfiber 16 µm	A06 Inorganic microfiber 6 µm	A25 Inorganic microfiber 25 µm	A10 Inorganic microfiber 10 µm	M25 Wire mesh 25 µm
A03 Inorganic microfiber 3 µm	A16 Inorganic microfiber 16 µm															
A06 Inorganic microfiber 6 µm	A25 Inorganic microfiber 25 µm															
A10 Inorganic microfiber 10 µm	M25 Wire mesh 25 µm															
	Element Δp					Execution										
	N 20 bar					P01 MP Filtri standard Pxx Customized										

FILTER ELEMENT

Element series and size	Configuration example: HP039 3 A03 A N P01												
HP039													
Element length	2 3 4												
Filtration rating (filter media)	<table border="0"> <tr> <td>A03 Inorganic microfiber 3 µm</td> <td>A16 Inorganic microfiber 16 µm</td> </tr> <tr> <td>A06 Inorganic microfiber 6 µm</td> <td>A25 Inorganic microfiber 25 µm</td> </tr> <tr> <td>A10 Inorganic microfiber 10 µm</td> <td>M25 Wire mesh 25 µm</td> </tr> </table>							A03 Inorganic microfiber 3 µm	A16 Inorganic microfiber 16 µm	A06 Inorganic microfiber 6 µm	A25 Inorganic microfiber 25 µm	A10 Inorganic microfiber 10 µm	M25 Wire mesh 25 µm
A03 Inorganic microfiber 3 µm	A16 Inorganic microfiber 16 µm												
A06 Inorganic microfiber 6 µm	A25 Inorganic microfiber 25 µm												
A10 Inorganic microfiber 10 µm	M25 Wire mesh 25 µm												
Seals	A NBR V FPM												
	Element Δp			Execution									
	N 20 bar			P01 MP Filtri standard Pxx Customized									

ACCESSORIES

Differential indicators	page		page
DEA Electrical differential indicator	567	DLE Electrical / visual differential indicator	570
DEH Hazardous area electronic differential indicator	567-568	DTA Electronic differential indicator	571
DEM Electrical differential indicator	568-569	DVA Visual differential indicator	571
DLA Electrical / visual differential indicator	569-570	DVM Visual differential indicator	571
Additional features	page		
T2 Plug	572		

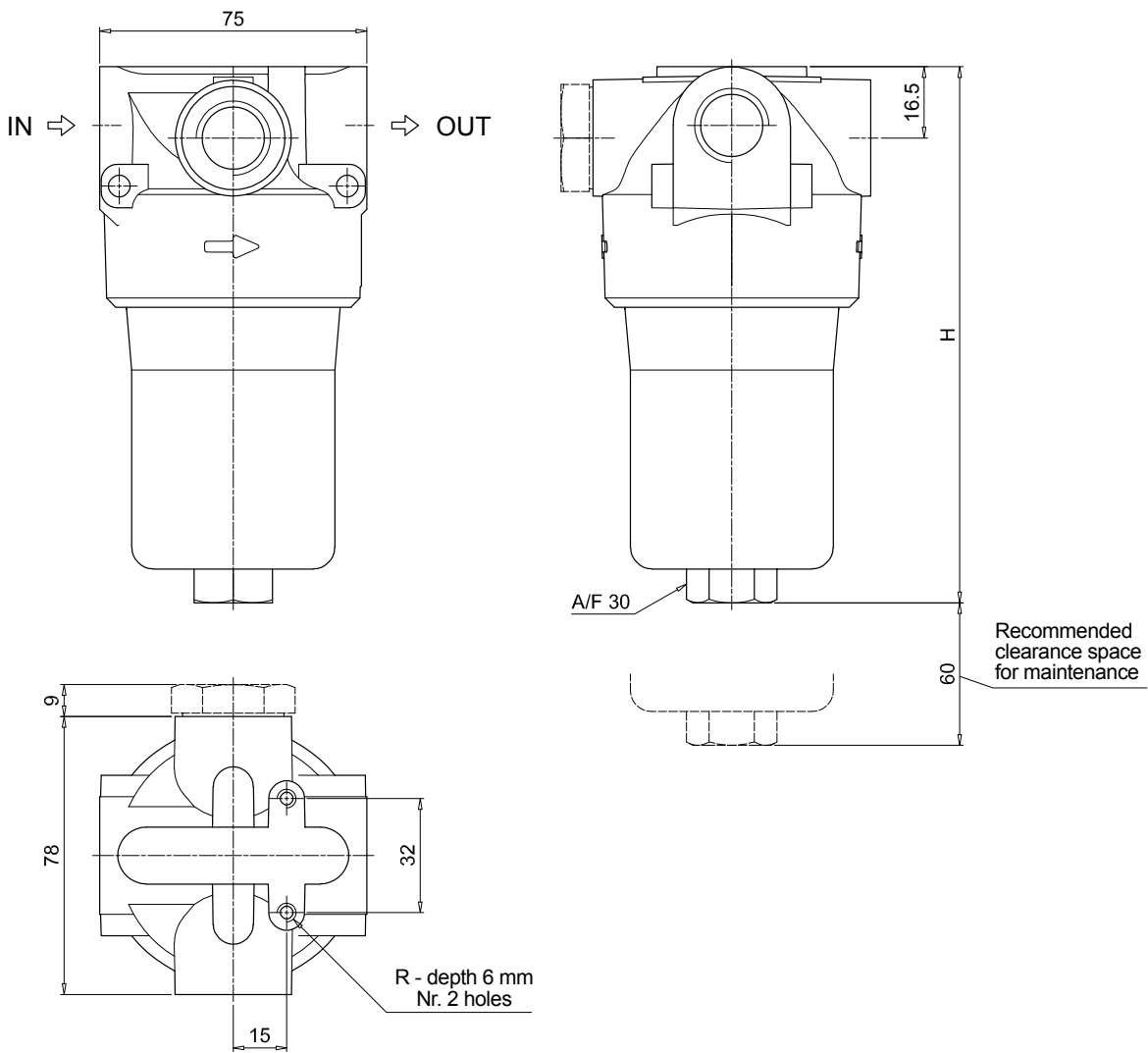

Version 1

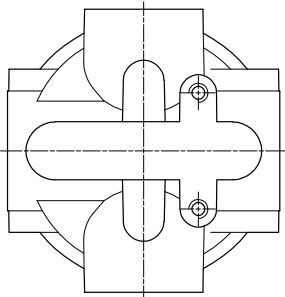

Version 6

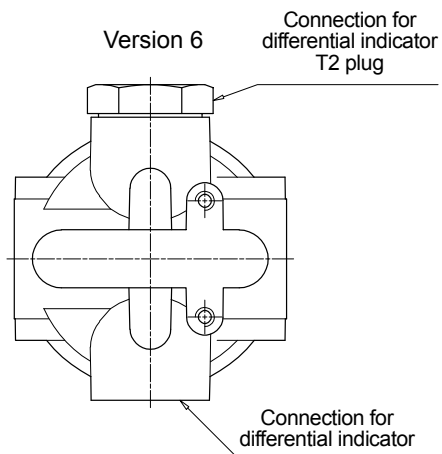

The position of the T2 plug is reversible

FMP039	
Filter length	H [mm]
2	151
3	194
4	238
Connections	R
A	M6
B - C	1/4" UNC

FMP 039 SPARE PARTS

Order number for spare parts

FMP 039

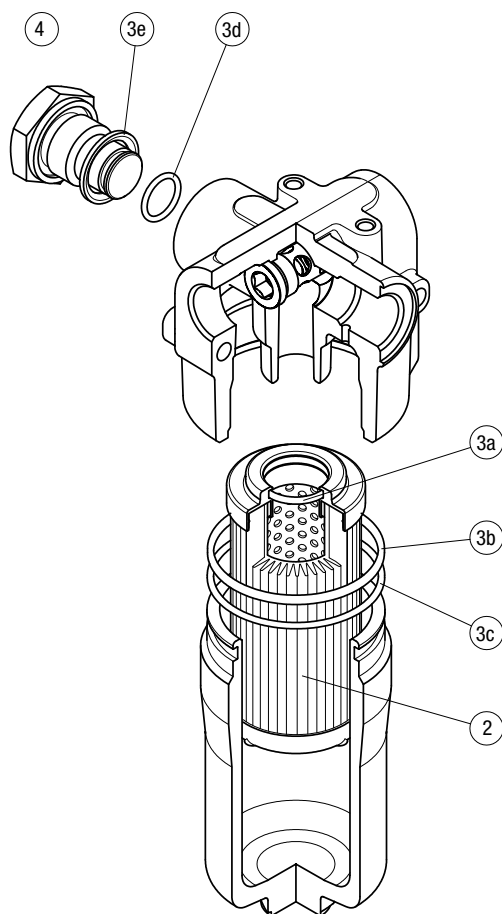

Item:	Q.ty: 1 pc.	Q.ty: 1 pc.	
Filter series	Filter element	Seal Kit code number	
		NBR	FPM
FMP 039	See order table	02050509	02050510