

SYMBOLS



P T B A

MPR-03P



P T B A

MPR-03A



P T B A

MPR-03B

HOW TO ORDER

MPR - 03 P - K - 0 - 30 - N

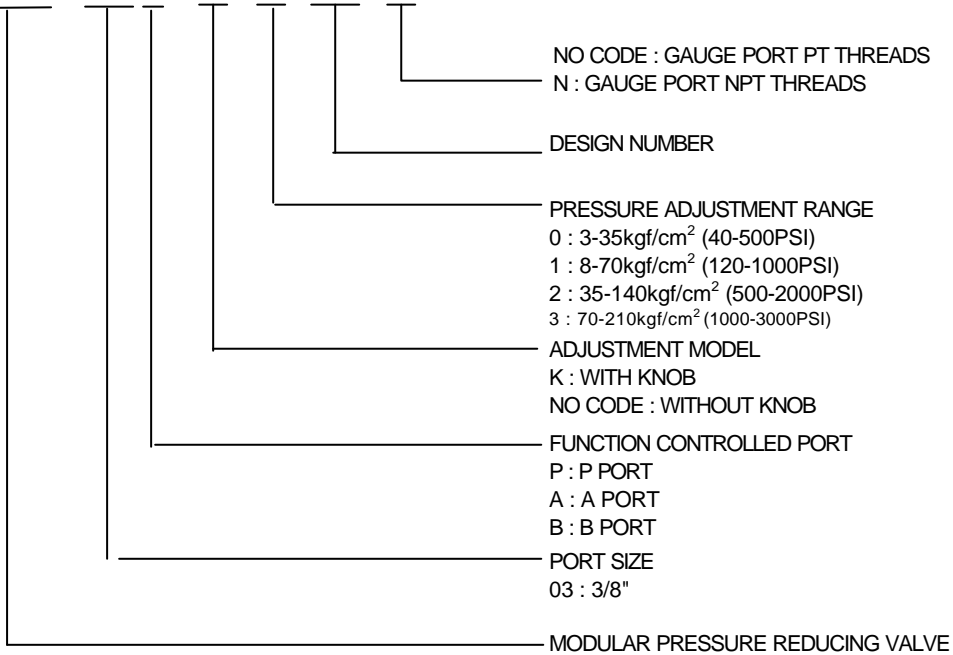

SPECIFICATIONS

MAX. OPERATING PRESSURE	210 kgf/cm ² (3000 PSI)
MAX. FLOW CAPACITY	70 LPM (20 GPM)

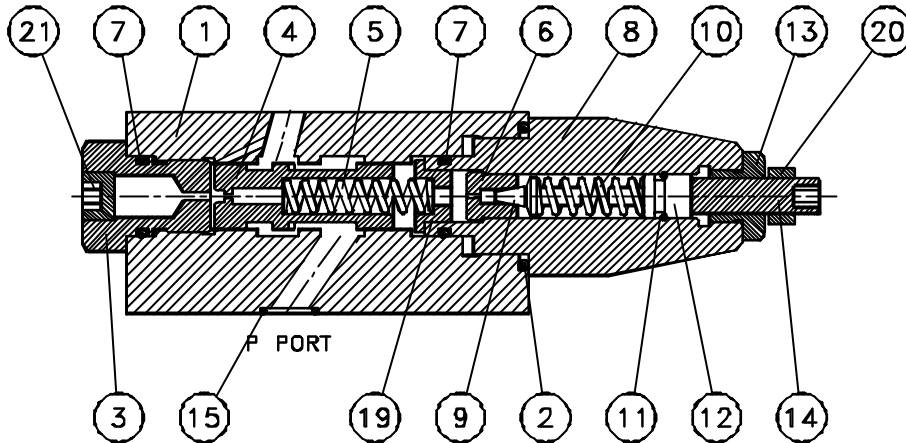

NO.	DESCRIPTION	SPEC.	NO.	DESCRIPTION	SPEC.
2	O-RING	G35(70°)	11	O-RING	P9(70°)
7	O-RING	P18(70°)	15	O-RING	AS568-014(90°)

PERFORMANCE CURVES

TEST FLUID VISCOSITY : 35 cSt (175 SSU)
TEST TEMPERATURE : 50°C (122°F)

PILLOT FLOW CHART

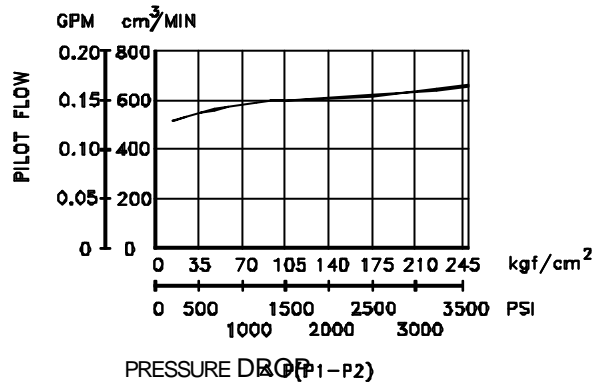

PRESSURE DROP AT SPOOL
FULLY OPENED (P-LINE)

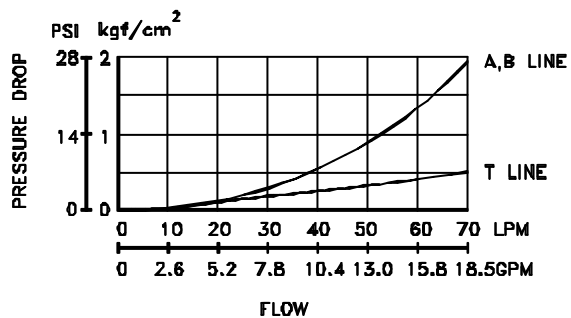
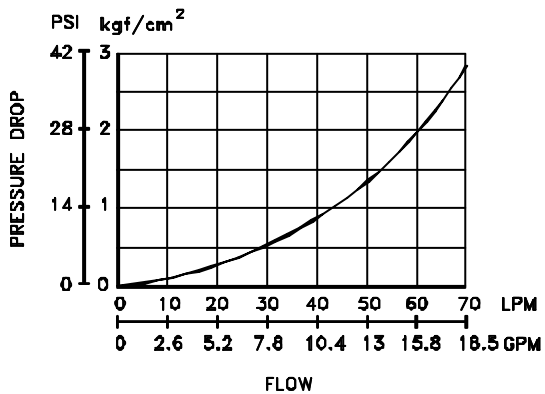

INSTALLATION DIMENSIONS

MPR - 03* - * - * - 30

UNIT: mm(inch)

WEIGHT : 3.4kgs(7.50lbs)

