

## SYMBOLS



MPR-02P



MPR-02A



MPR-02B

## HOW TO ORDER

**MPR - 02 P - K - 1 - 20 - N**

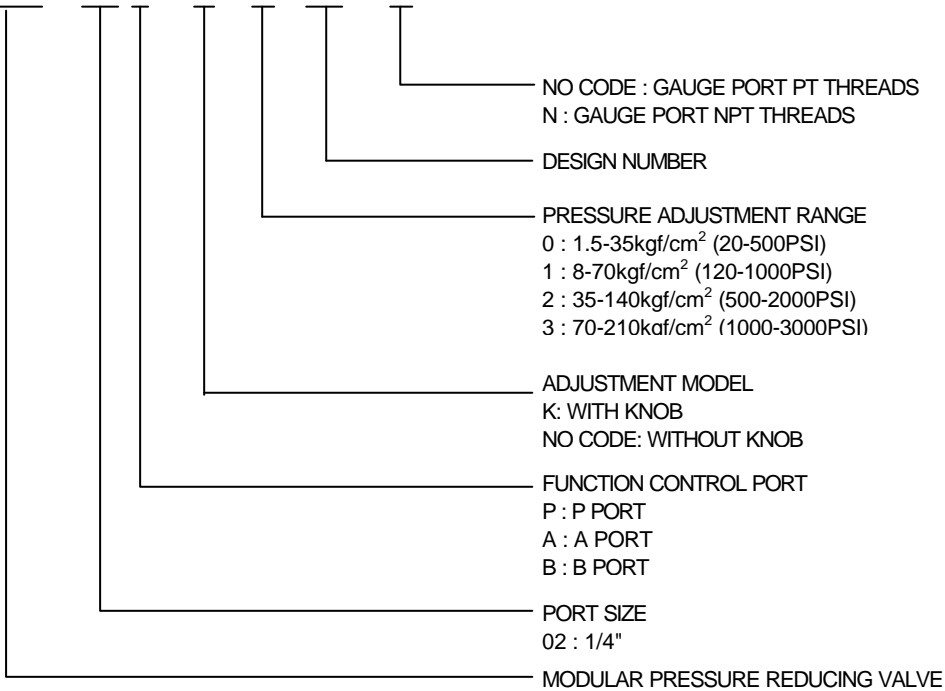

## SPECIFICATIONS

MAX. OPERATING PRESSURE	210 kgf/cm <sup>2</sup> (3000 PSI)
MAX. FLOW CAPACITY	35 LPM (9.3 GPM)

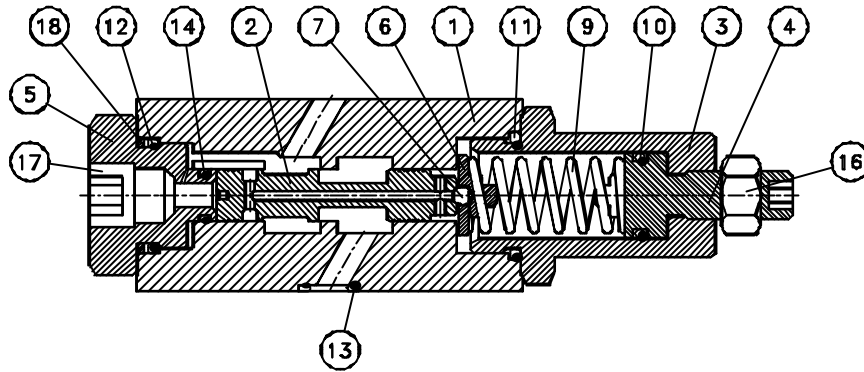

NO.	DESCRIPTION	SPEC.	NO.	DESCRIPTION	SPEC.
10	O-RING	P14(70°)	13	O-RING	AS568-02(90°)
11	O-RING	P22(90°)	14	O-RING	P8(70°)
12	O-RING	P20(90°)	18	BACK-UP RING	P20

## PERFORMANCE CURVES

TEST FLUID VISCOSITY : 35 cSt (175 SSU)

TEST TEMPERATURE : 50°C (122°F)

### PRESSURE DROP

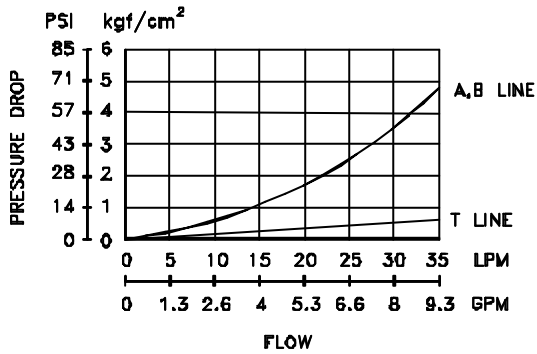

### PRESSURE DROP AT SPOOL FULLY OPENED

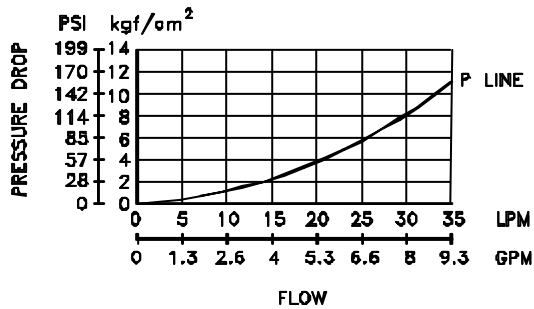

### MIN. ADJUSTMENT PRESSURE VS. MAX. FLOW

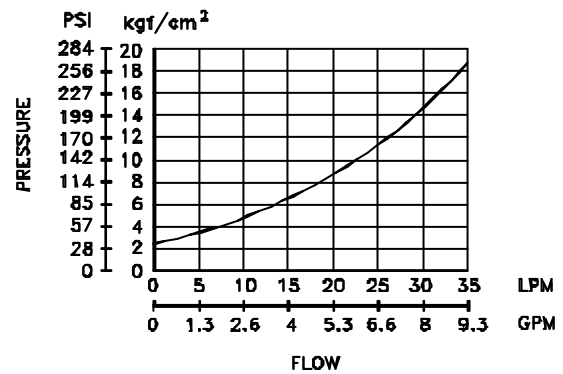

## INSTALLATION DIMENSIONS

MPR - 02B - \* - \* - 20

UNIT: mm(inch)

WEIGHT: 1.2 kgs(2.65 lbs)

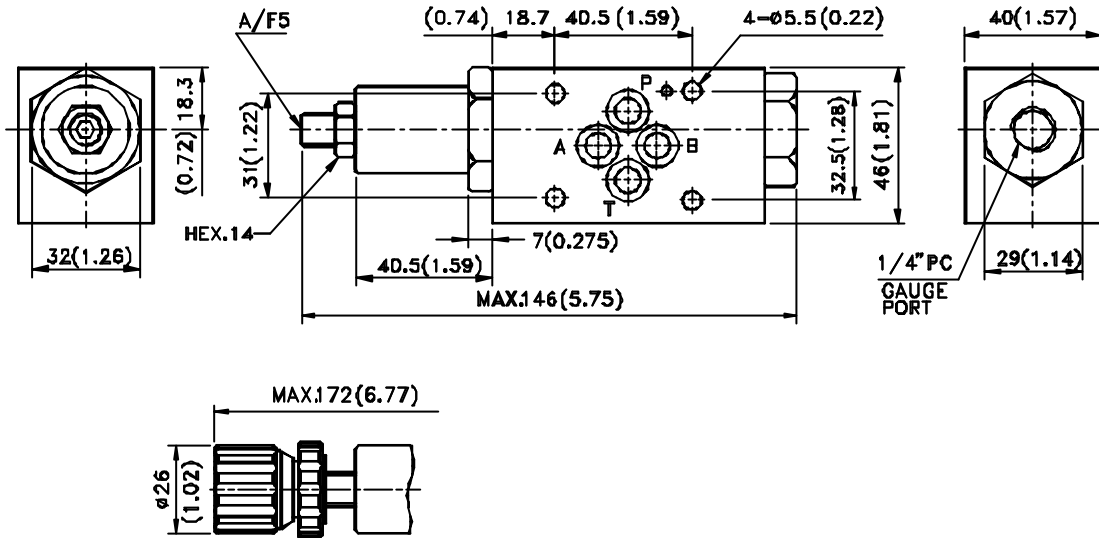

MPR - 02P/A - \* - \* - 20

