

Schema idraulico
 Hydraulic diagram

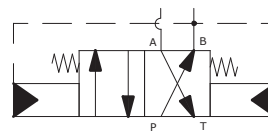

CARATTERISTICHE TECNICHE
CHARACTERISTICS

Maximum operating pressure on port P	bar	320
Maximum flow rate	l/min	100
Minimum allowed flow rate	l/min	10
Minimum allowed pressure	l/min	60
Pressure drop Δp -Q	see paragraph	
Ambient temperature range	°C	-20 / +50
Fluid temperature range	°C	-20 / +80
Fluid viscosity range	cSt	10 + 400
Fluid contamination degree	according to ISO 4406:1999 class 20/18/15	
Recommended viscosity	cSt	25
Mass	kg	3

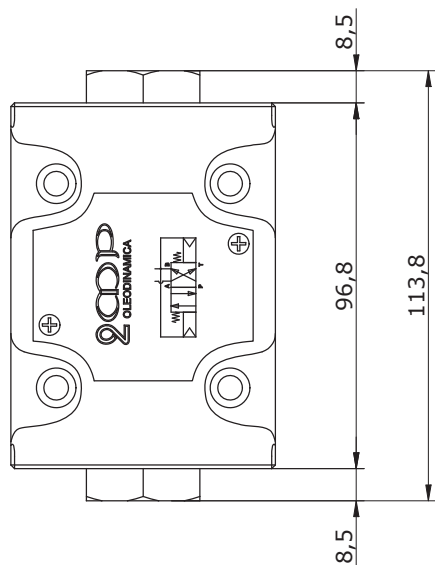
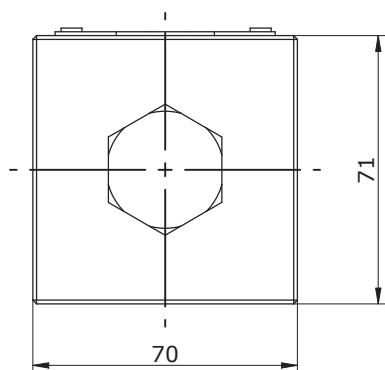

PERDITE DI CARICO
PRESSURE DROPS

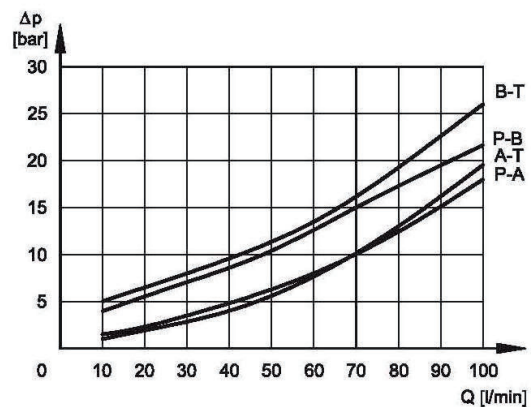

ES 610 - 42