

CAST IRON PUMPS AND MOTORS **W3 SERIES**

POMPE E MOTORI IN GHISA SERIE W3

MADE IN ITALY

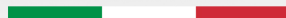

Ronzio Oleodinamica fu fondata nel 1950 da Dante Ronzio esperto in meccanica di precisione.

La prima attività dell'azienda fu la lavorazione di pompe per motori diesel, seguita, qualche anno più tardi, dalla costruzione di pompe oleodinamiche ad ingranaggi, che presto divenne la produzione prevalente.

La passione del fondatore per la meccanica fine ha lasciato nella Ronzio Oleodinamica un'impronta significativa; il motto dell'azienda è sempre stato quello di operare all'insegna della qualità e precisione, sia nell'impiego delle materie prime sia nel controllo del processo produttivo.

Ronzio Oleodinamica produce ora pompe, motori e divisori di flusso che trovano impiego in molti settori industriali sia nel veicolo che negli impianti fissi, nelle macchine agricole, forestali e nel movimento terra.

La struttura snella della nostra azienda e la nostra esperienza sono la risposta ai clienti che cercano in noi non solo un fornitore ma un partner nello sviluppo dei loro progetti.

Il nostro sistema qualità è certificato da DNV dal 1998.

Ronzio Oleodinamica was established in 1950 by Mr. Dante Ronzio, fond of precision mechanics.

The company started its activity machining pumps for diesel motors. The passion of the founder for fine mechanics left an important mark in the company. The production of hydraulic gear pumps started some years later, and became soon the main activity of the company.

Since the beginning Ronzio Oleodinamica has been focusing on quality and precision. Our Company uses top quality components and the most advanced computerized machines, both in the production and in the testing process.

Ronzio Oleodinamica manufactures gear pumps, motors and flow dividers in aluminium and in cast iron for a wide range of industries including: constructions, forestry, agriculture, industrial vehicles, earth moving, industrial.

Today, our products are worldwide appreciated.

Our experience and our lean structure are suitable for customers who need a direct involvement of the supplier in their projects.

Caratteristiche principali

- Corpi e coperchi in ghisa per maggiori prestazioni.
- Possibilità di funzionare ad alte pressioni: fino a 300 bar di pressione massima in funzionamento continuo.
- Compensazione assiale per il recupero dei giochi.
- Alto rendimento volumetrico: >95% medio.
- Progetto accurato del profilo del dente per avere una bassa rumorosità.
- Vasta gamma di flange, alberi e connessioni compatibili con i principali standard del mercato.
- Disponibilità di guarnizioni per alte temperature.
- Pompe e motori unidirezionali.
- Pompe e motori bidirezionali.
- Possibilità di montaggio di pompe multiple prodotte da Ronzio Oleodinamica.

Main Features

- *Cast iron covers and body for high Performance.*
- *High pressure option: up to 300 bar max. continuous pressure (4350 psi).*
- *Axial compensation achieved using pressure balanced bushing blocks.*
- *High volumetric efficiency: average >95%*
- *Gear tooth profile accurately projected providing low noise operation.*
- *A wide variety of shafts, flanges and ports are available to meet specific application requirements.*
- *High-temperature seals available.*
- *Single rotational pumps and motors.*
- *Bi-rotational pumps and motors.*
- *Multiple pumps availability: tandem pumps are possible both with other series produced by Ronzio Oleodinamica.*

CONDIZIONI PER L'UTILIZZO DELLE POMPE E MOTORI "W3" **USE CONDITIONS FOR PUMPS AND MOTORS "W3"**

Nell'utilizzo della pompa evitare carichi radiali e assiali sull'albero, dove si verificano utilizzare gli appositi supporti illustrati in questo catalogo.

Il giunto di trascinamento deve compensare eventuali errori di allineamento, deve essere di tipo elastico oppure di tipo Oldham.

Per un corretto funzionamento e una lunga durata della pompa, osservare i valori riportati nella tabella seguente.

Avoid radial and axial loads on the pump shaft during the use, where it happens use outboard bearing illustrated in this catalogue.

The pump must be in line with the P.T.O. to compensate misalignment errors, use flexible or "Oldham" coupling.

We recommend to read the specifications in this catalogue very carefully. This will help you in getting the best, in terms of working conditions and life, from Ronzio gear pumps.

CONDIZIONI DI UTILIZZO USE CONDITIONS

Fluidi idraulici Hydraulic fluids	<p>Oli idraulici a base minerale (DIN 51524). Per utilizzo di fluidi non infiammabili come acqua e glicole, emulsione di olio in acqua o esteri fosforici, contattare il nostro ufficio tecnico o commerciale.</p> <p>Mineral oil (DIN 51524). For use with fire resistant fluids like water glycol, water-oil emulsion and phosphate-esters, please contact our technical or commercial office.</p>		
Pressione in aspirazione Inlet pressure	0.7 - 3 bar (Assoluti / Absolute) 10 - 44 psi (Assoluti / Absolute)		
Velocità olio nella linea di aspirazione Oil speed on suction line	0.5 ÷ 1.5 m/s		
Velocità olio nella linea di mandata Oil speed on pressure line	6 ÷ 10 m/s		
Temperatura olio Oil temperature	-10°C ÷ 80°C		
Viscosità olio Oil viscosity	20 ÷ 120 mm ² / s (Cst)		
Massima viscosità olio all'avvio Max starting viscosity	700 mm ² / s (Cst)		
Filtraggio olio Oil filtration	Pressione Pressure	< 200 bar	> 200 bar
	Classe di contaminazione NAS 1638 Contamination class NAS 1638	10	9
	Classe di contaminazione ISO 4406 Contamination class ISO 4406	19/16	18/15
	Rapporto β _x ≥ 75 Ratio β _x ≥ 75	25μm	10μm

FORMULE PER DIMENSIONAMENTO DETERMINATION OF NOMINAL SIZE

PER POMPE
FOR PUMP

$$Q = \frac{V * \eta_v * n}{1000}$$

$$M = \frac{p * V}{62.8 * \eta_m}$$

$$P = \frac{p * Q}{600 * \eta_t}$$

PER MOTORI
FOR MOTOR

$$Q = \frac{V * n}{1000 * \eta_v}$$

$$M = \frac{p * V * \eta_m}{62.8}$$

$$P = \frac{p * Q * \eta_t}{600}$$

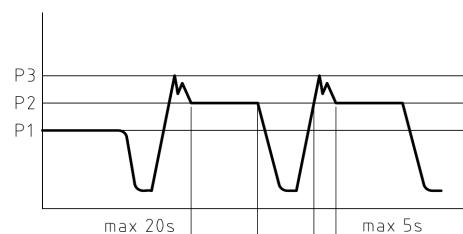

V [cm³]
Q [l/min]
p [bar]
M [Nm]
n [min⁻¹]
P [Kw]

η_v = EFF vol. ≥ 95
η_m = EFF mecc. ~ 0.85
η_t = η_v * η_m. ~ 0.8

CARATTERISTICHE PRINCIPALI MAIN CHARACTERISTICS

Tipo - Type		15	20	25	30	35	40	45	50	55	60	64	70	80	90
Cilindrata Capacity	Cm ³ /giro Cm ³ /rev	15.5	19.9	24.9	29.9	34.3	40.5	45.2	49.9	54.5	60	63.9	70	78.7	89.6
Portata a 1500 giri / min Delivery at 1500 rev. / min	l / min l / min	25.9	29.9	37.4	44.9	51.5	60.8	67.8	74.9	81.8	90	95.9	105	118	134.4
P1 Pressione max continua Max working pressure	Bar	300	300	300	280	280	250	250	230	230	200	200	170	170	160
P2 Pressione intermittente intermittent pressure	Bar	320	320	320	300	300	270	270	250	250	220	220	190	190	180
P3 Pressione max di picco Max peak pressure	Bar	350	350	350	330	330	300	300	270	270	240	240	210	210	200
Velocità max per pressione P1 Max speed for P1 pressure	Giri / min Rpm	3000	3000	3000	2500	2500	2200	2200	2000	2000	2000	2000	1800	1800	1800
Velocità max a vuoto Max speed without load	Giri / min Rpm	3500	3500	3500	3000	3000	2800	2800	2500	2500	2500	2500	2200	2200	2200
Velocità min. per pressione P1 Min speed for P1 pressure	Giri / min Rpm	450	450	450	350	350	350	350	300	300	250	250	200	200	200

VERIFICARE, ATTRAVERSO LE FORMULE A PAGINA 4, LA COMPATIBILITÀ TRA LE PRESTAZIONI DI PRESSIONE E PORTATA RICHIESTE E LA CAPACITÀ DELL' ALBERO DI TRASCINAMENTO DI SOPPORTARE LA COPPIA RICHIESTA.

VERIFY THE COMPATIBILITY AMONG PERFORMANCE OF PRESSURE, FLOW REQUIRED AND TORQUE OF THE SHAFT THROUGH THE FORMULAS ON PAGE 4.

Per pompe o motori bidirezionali, diminuire la pressione del 15%.
With bidirectional pumps or motors, pressure is reduced by 15%.

COMPONENTI

PARTS

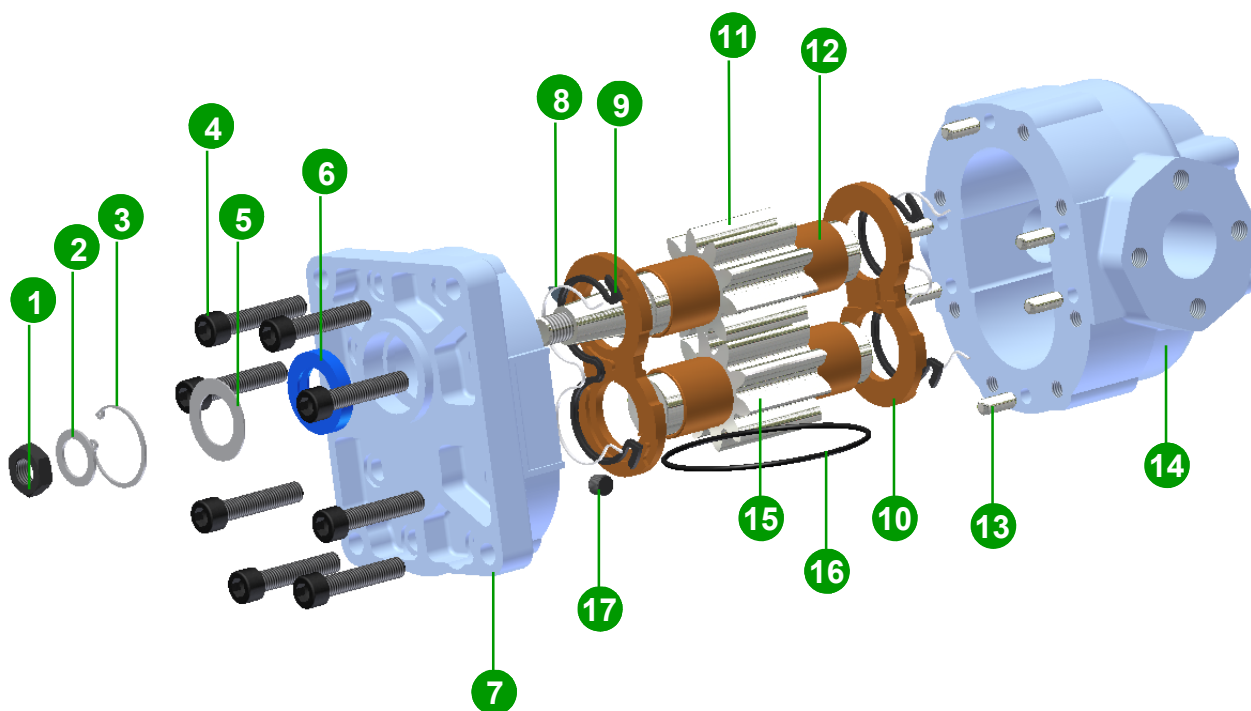

Rif.	Descrizione	Description	Qt.
1	Dado	Hexagonal nut	1
2	Rondella di sicurezza	Safety ring	1
3	Anello seeger	Snap ring	1
4	Vite	Bolt	8
5	Rondella anello di tenuta	Rotary shaft seal ring	1
6	Anello di tenuta	Rotary shaft seal	1
7	Coperchio	Front flange	1
8	Antiestrusore	B-K seals	2
9	Guarnizione di compensazione	Compensation seal	2
10	Rasamento	Thrust plates	2
11	Ingranaggio conduttore	Drive gear	1
12	Boccola	Bushing	4
13	Spina cilindrica	Pin	6
14	Corpo	Housing	1
15	Ingranaggio condotto	Idle gear	1
16	Guarnizione sotto coperchio	Under cover seal	1
17	Grano 1/8" G	Grub screw 1/8" G	1

SENSO DI ROTAZIONE

ROTATION

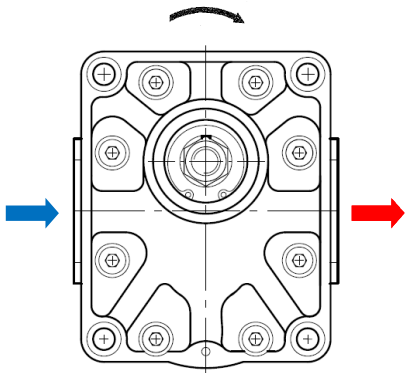

Rotazione destra Clockwise rotation	Codice Code	D
--	----------------	----------

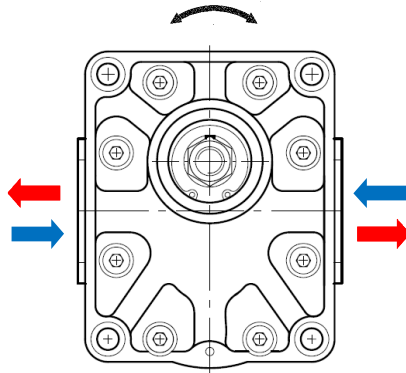

Rotazione bidirezionale drenaggio esterno Bidirectional rotation with external drain	Codice Code	R
---	----------------	----------

Rotazione bidirezionale drenaggio interno Bidirectional rotation with internal drain	Codice Code	Y
---	----------------	----------

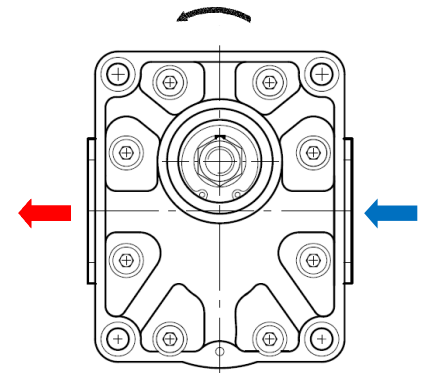

Rotazione sinistra Anti-Clockwise rot.	Codice Code	S
---	----------------	----------

Il senso di rotazione è indicato con una freccia sul corpo della pompa.
Rotation is indicated by an arrow on the body of the pump.

GUARNIZIONI PER ALBERI

SHAFT SEAL

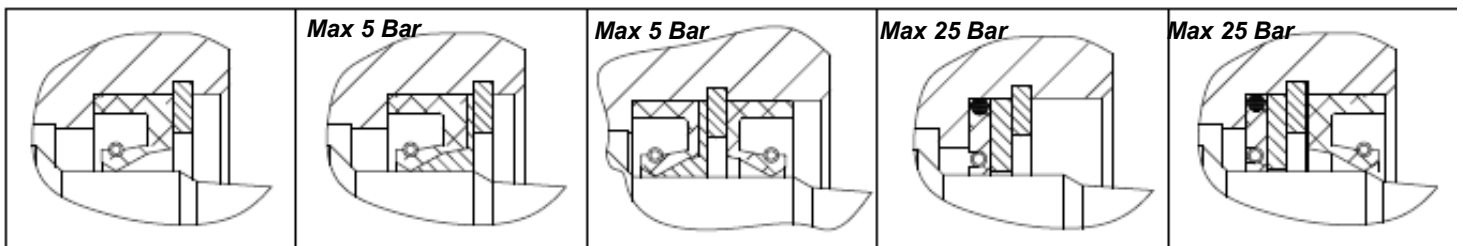

Codice Code	N	NBR
	V	FKM
	H	HNBR

Codice Code	R	NBR
	RV	FKM
	RH	HNBR

Codice Code	N2	NBR
	V2	FKM

Codice Code	B	//
----------------	----------	-----------

Codice Code	BN	NBR
	BV	FKM

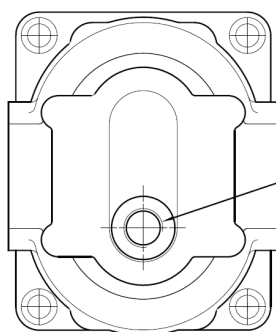

G3/8" - 9/16-18UNF-2B

G 3/8" PER BOCHE GAS E METRICHE.
9/16-18UNF-2B PER BOCHE O-RING BOSS e SAE FLANGIATE

G3/8" FOR GAS AND METRIC PORTS
9/16-18UNF-2B FOR O-RING BOSS AND SAE "FLANGED"

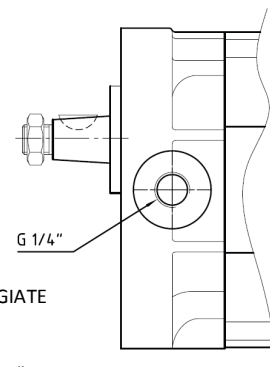

G 1/4"

Drenaggio posteriore per pompe o motori reversibili. Rear drain for bidirectional pumps or motors.	R0
---	-----------

Drenaggio anteriore per pompe o motori reversibili. Front drain for pumps or motors.	R1
---	-----------

CAMBIO DEL SENSO DI ROTAZIONE DELLE POMPE W3 CHANGING ROTATION OF THE PUMP W3

Rotazione destra
Clockwise rotation

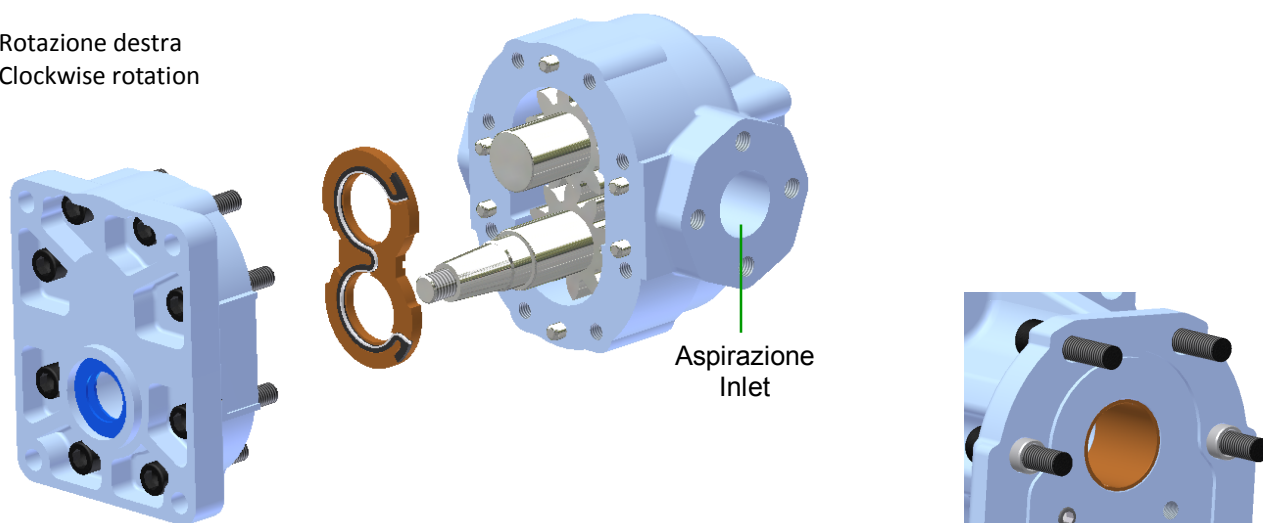

Rotazione sinistra
Anticlockwise rotation

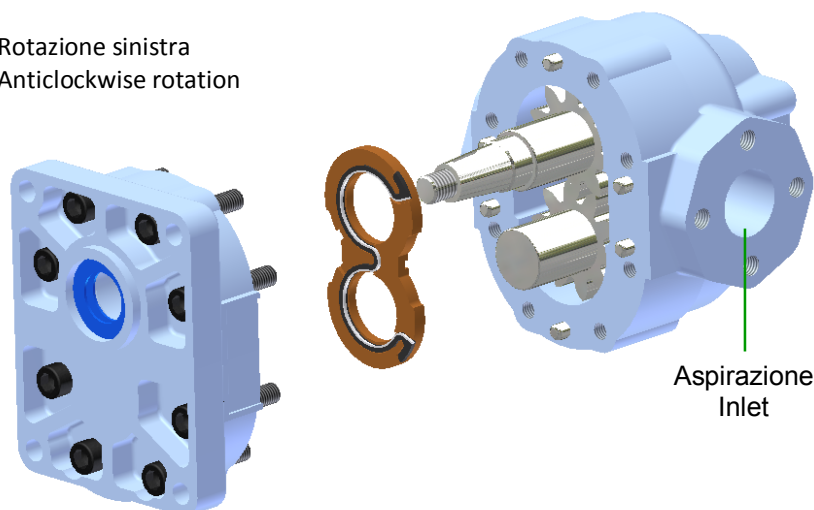

Il senso di rotazione è indicato con una freccia sul corpo della pompa.
An arrow on the housing of the pump indicates the rotation.

- Svitare le viti di fissaggio.
- Rimuovere la flangia tenendo premuto l'ingranaggio conduttore.
- Rimuovere contemporaneamente l'ingranaggio conduttore e il rasamento superiore mantenendo premuto l'ingranaggio condotto.
- Estrarre l'ingranaggio condotto tenendo fermo il rasamento inferiore, nel caso aiutarsi con una barretta NON metallica.
- Rimontare i due ingranaggi con posizioni invertite (vedi schema sopra).
- Rimontare il rasamento superiore facendo attenzione a NON invertirne la posizione.
- Cambiare di posizione al grano situato sulla faccia interna della flangia.
- Rimontare la flangia utilizzando per le viti una coppia di serraggio di 60-65 Nm.

- *Unscrew the clamping bolts.*
- *Remove the flange holding down the drive gear.*
- *Remove the drive gear and the bushing block holding down the idle gear.*
- *Remove the idle gear keeping down the rear bushing block with a no-metallic bar.*
- *Reverse the position of the two gears (see picture above).*
- *Replace the bushing block without rotate or changing position.*
- *Changing position of the grub screw on the flange (see picture above).*
- *Reverse the flange and retighten the bolts to a torque rating between 44-48 ft/lbs.*

DIMENSIONI CORPO W3
HOLDING W3 DIMENSIONS

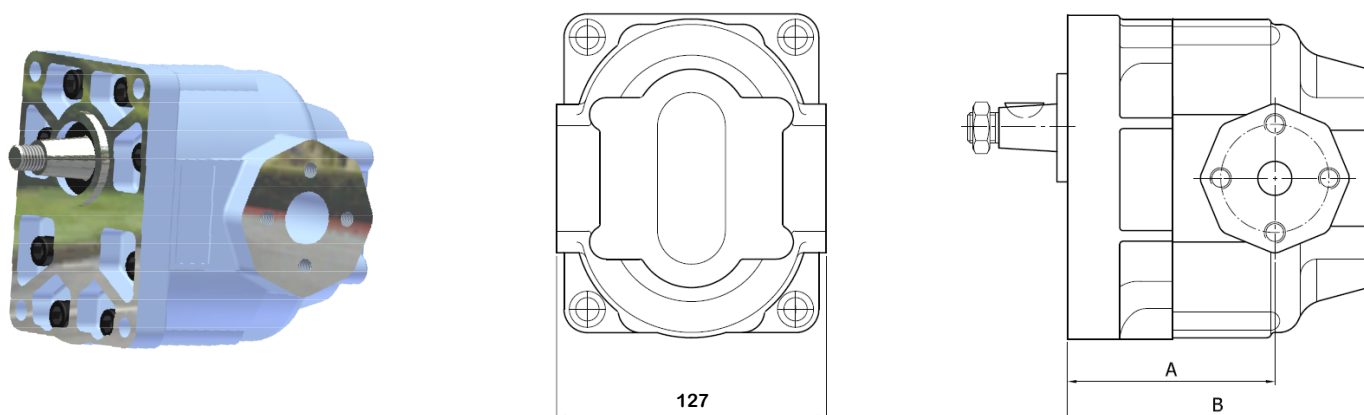

Tipo - Type		15	20	25	30	35	40	45	50	55	60	64	70	80
A	mm	70	76	76	79	82	82	85	85	85	89	89	90	95
B	mm	115	120	127	127	127	127	127	127	127	132	132	132	132

DIMENSIONI CORPO W3L
HOLDING W3L DIMENSIONS

Bocche posteriori
Rear ports

CODICE / CODE
J

Bocche laterali
Lateral ports

CODICE / CODE
X

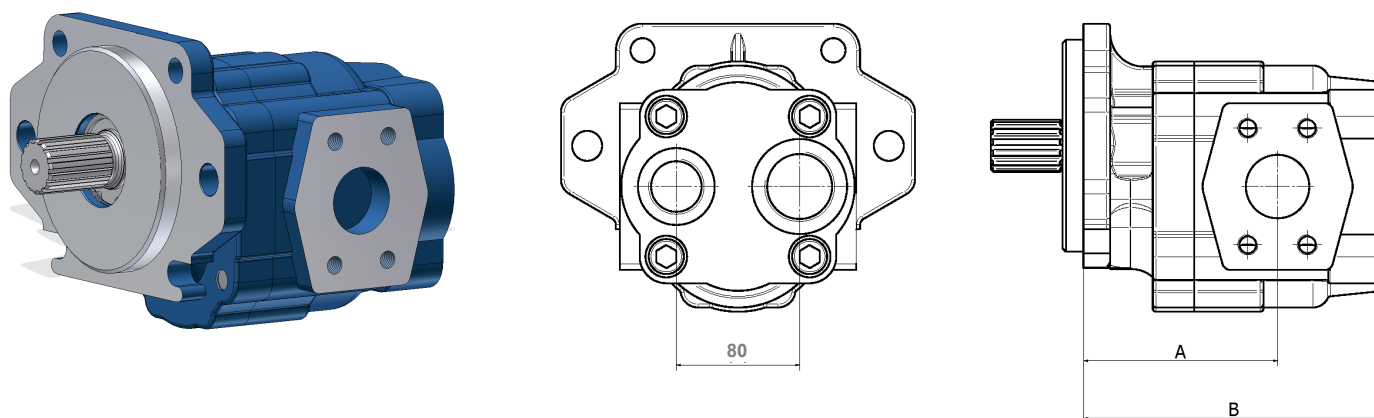

Tipo - Type		20	25	30	35	40	45	50	55	60	64	70	80	90
A	mm	103	106	110	112	108	110	114	116	105	107	111	116	116
B	mm	142	145	149	152	156	158	162	165	168	170	174	180	180

FLANGE
FLANGES

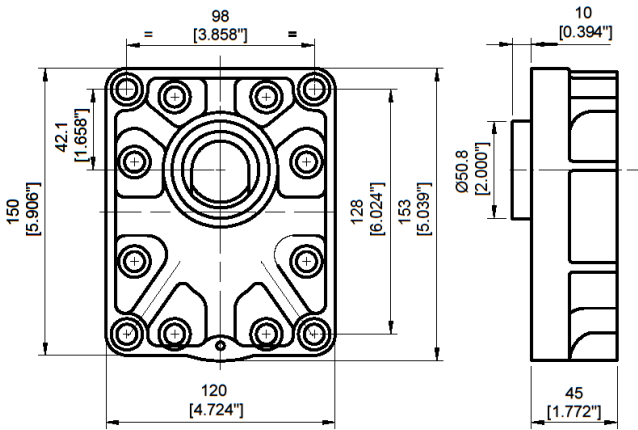

CODICE
CODE **A 0**

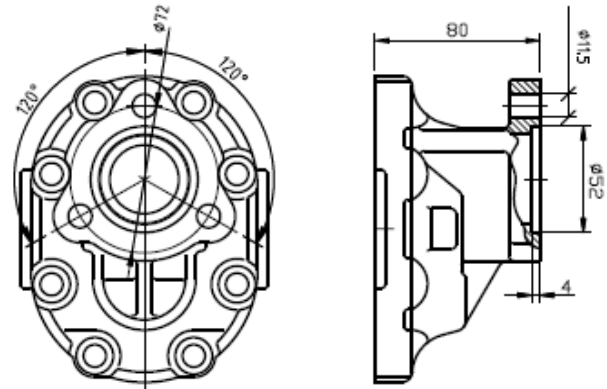

CODICE
CODE **N 7**

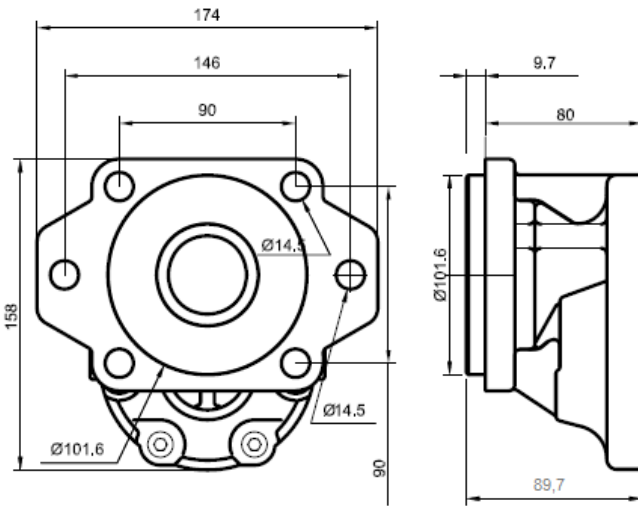

CODICE
CODE **B 3**

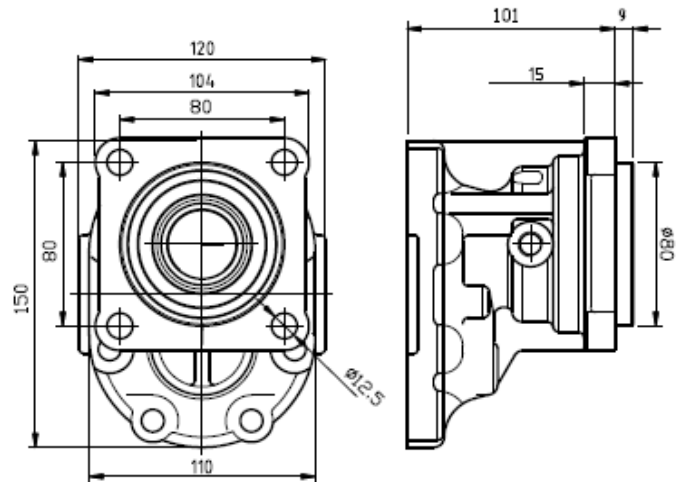

CODICE
CODE **I 4**

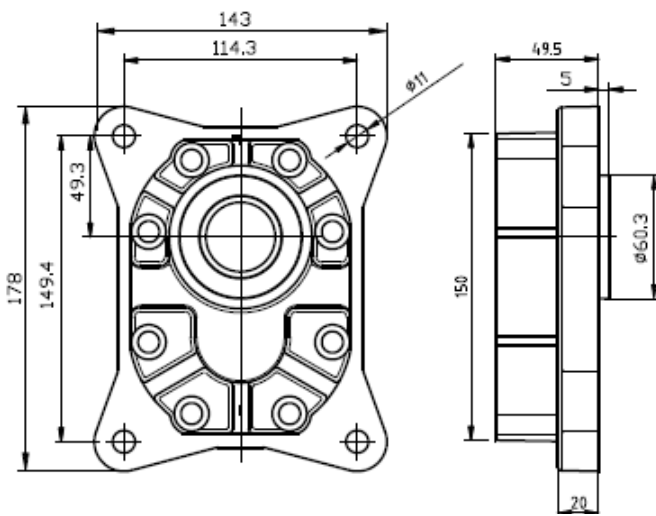

CODICE
CODE **D 5**

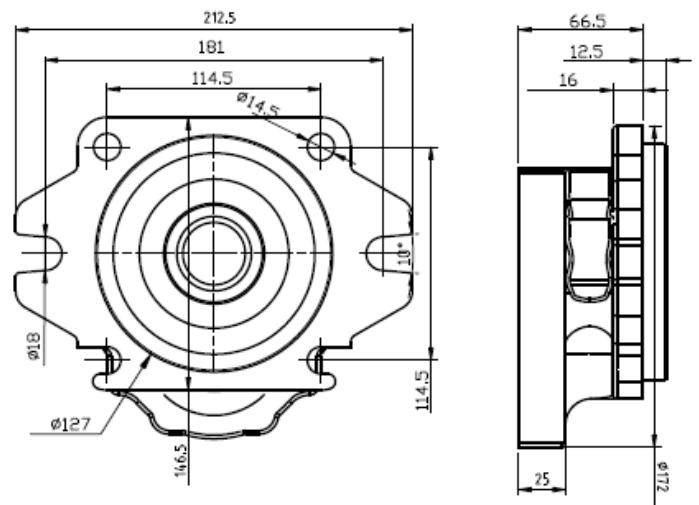

CODICE
CODE **C 6**

FLANGE
FLANGES

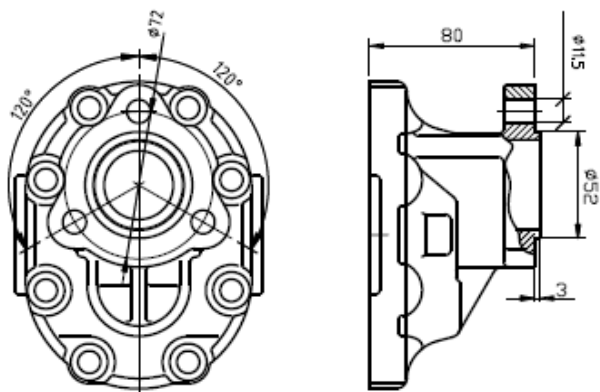

CODICE
CODE

N 8

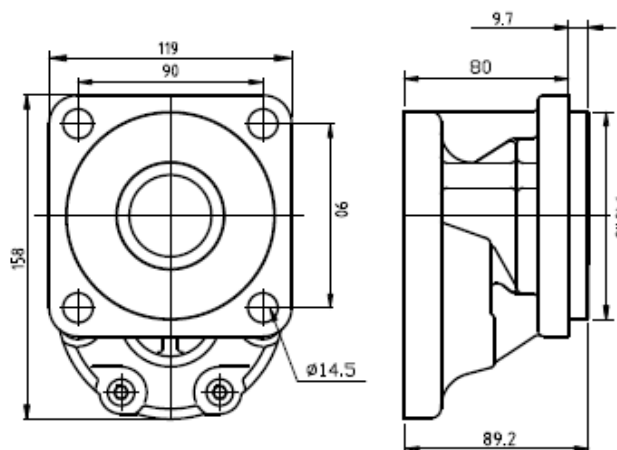

CODICE
CODE

L 3

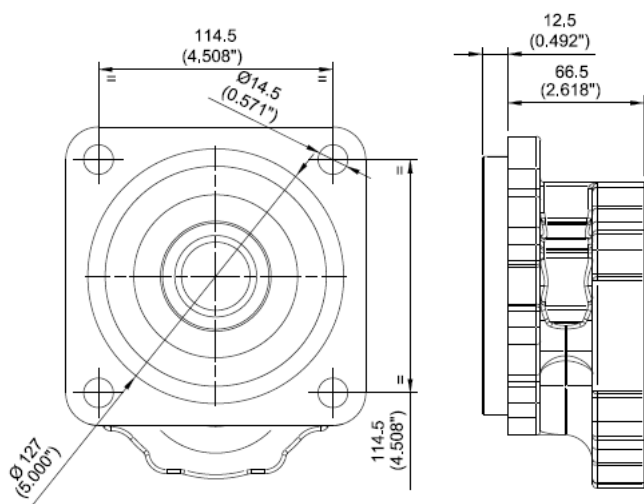

CODICE
CODE

E 6

ALBERI
SHAFTS

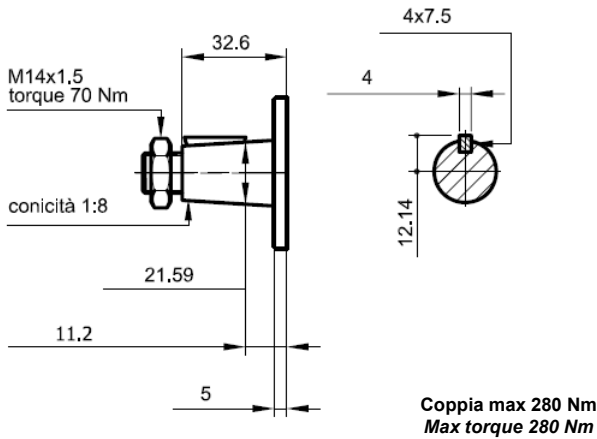

CODICE / CODE	C
PER FLANGIA / FOR FLANGE	A 0

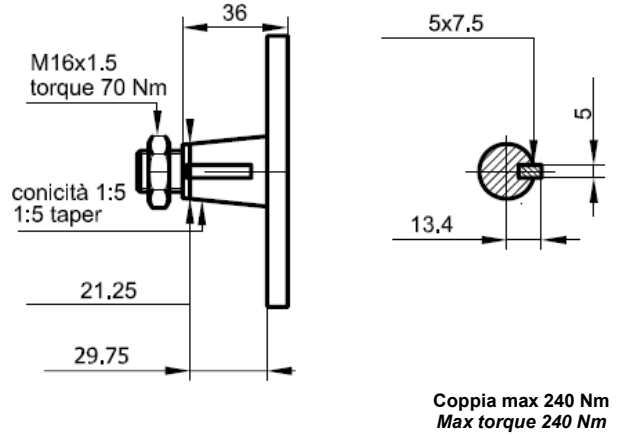

CODICE / CODE	A
PER FLANGIA / FOR FLANGE	G 4

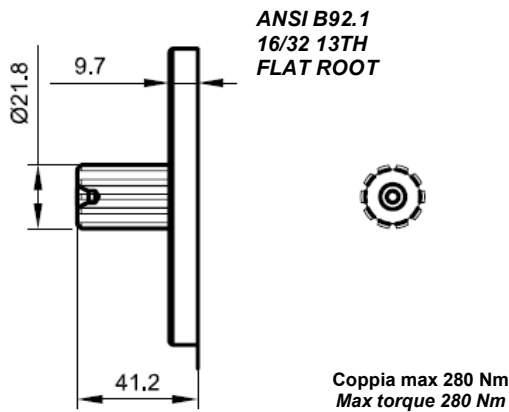

CODICE / CODE	B
PER FLANGIA / FOR FLANGE	L 3
	B 3

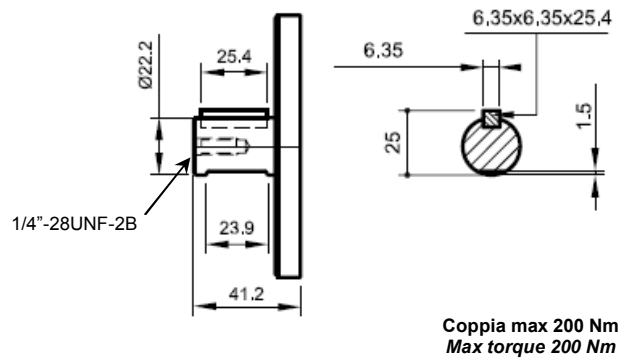

CODICE / CODE	L
PER FLANGIA / FOR FLANGE	L 3
	B 3

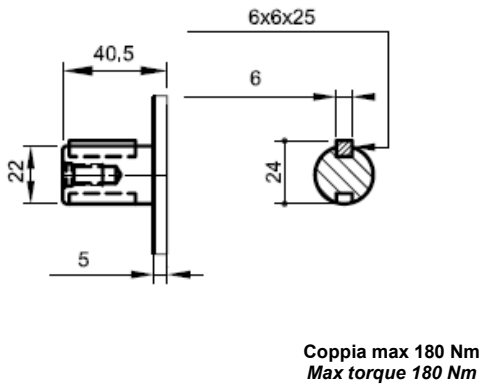

CODICE / CODE	Q
PER FLANGIA / FOR FLANGE	A 0
	D 5

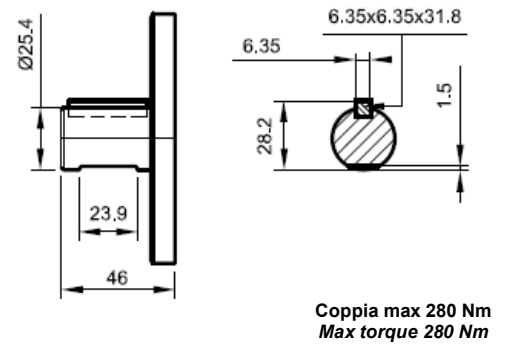

CODICE / CODE	D
PER FLANGIA / FOR FLANGE	L 3
	B 3

ALBERI
SHAFTS

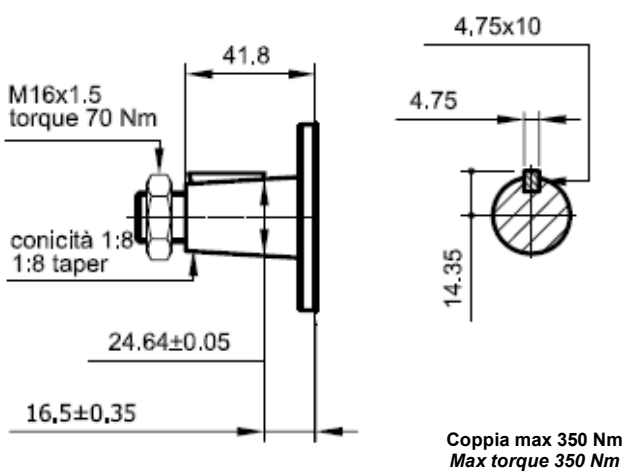

CODICE / CODE	E
PER FLANGIA / FOR FLANGE	D 5

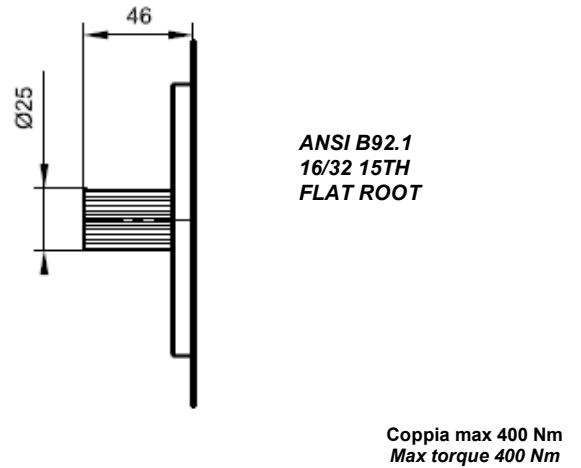

CODICE / CODE	S
PER FLANGIA / FOR FLANGE	L 3
	B 3

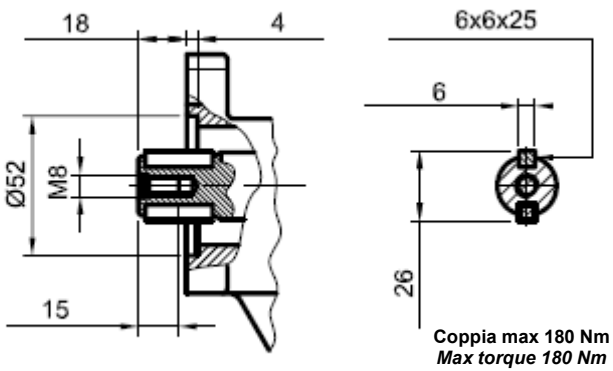

CODICE / CODE	N
PER FLANGIA / FOR FLANGE	N 7

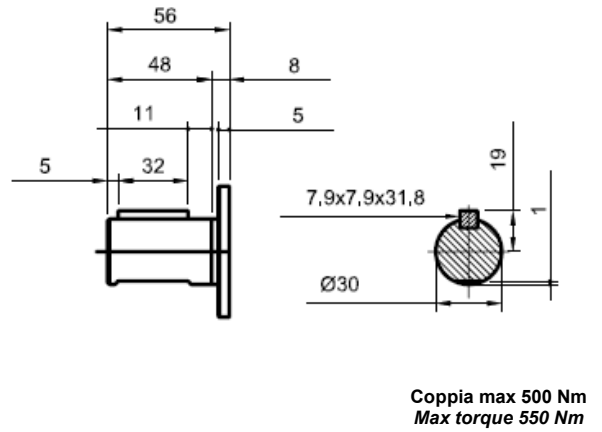

CODICE / CODE	G
PER FLANGIA / FOR FLANGE	D 5

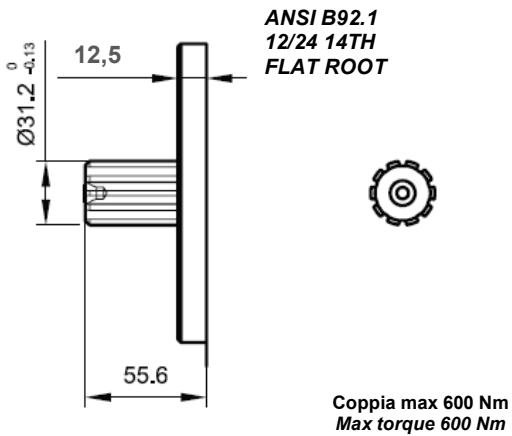

CODICE / CODE	K
PER FLANGIA / FOR FLANGE	C 6
	E 6

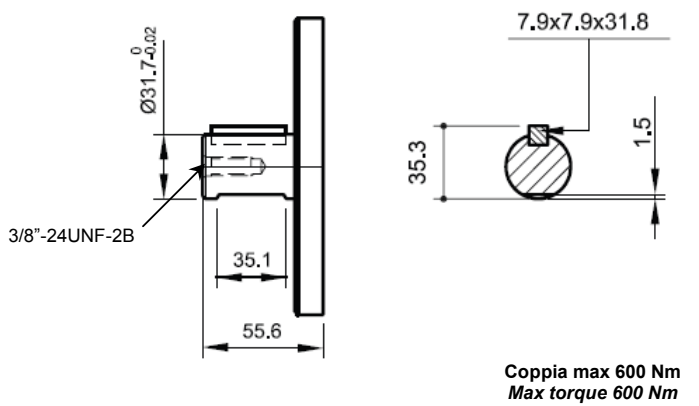

CODICE / CODE	P
PER FLANGIA / FOR FLANGE	C 6
	E 6

ALBERI
SHAFTS

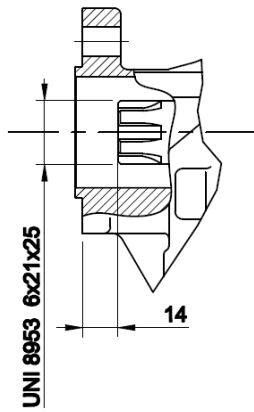

Coppia max 280 Nm
Max torque 280 Nm

CODICE / CODE	F
PER FLANGIA / FOR FLANGE	N 8

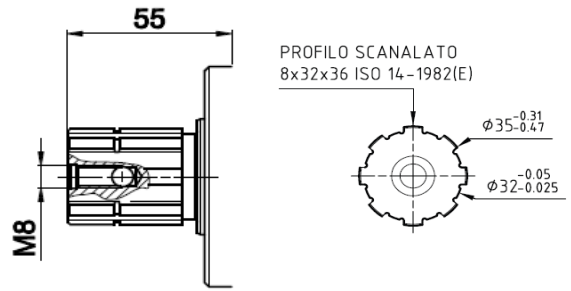

Coppia max 280 Nm
Max torque 280 Nm

CODICE / CODE	H
PER FLANGIA / FOR FLANGE	I 4

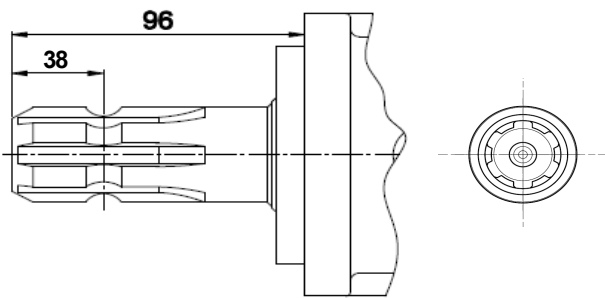

1"-3/8 DIN 9611 -Z6

Coppia max 280 Nm
Max torque 280 Nm

CODICE / CODE	M
PER FLANGIA / FOR FLANGE	I 4

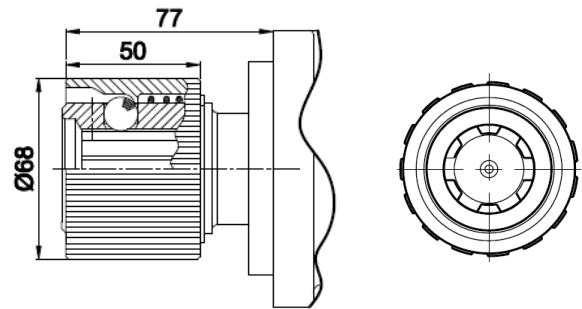

1"-3/8 DIN 9611 -Z6

Coppia max 280 Nm
Max torque 280 Nm

CODICE / CODE	R
PER FLANGIA / FOR FLANGE	I 4

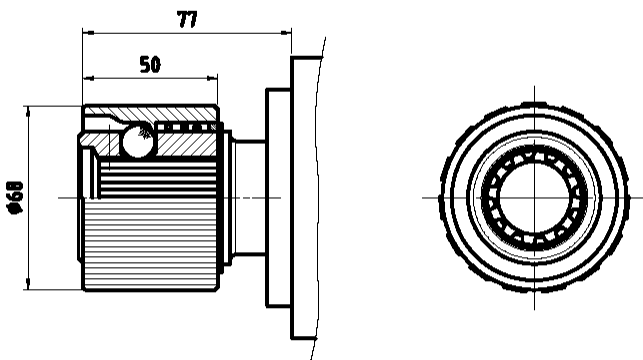

1"-3/8 DIN 9611 -Z21

Coppia max 280 Nm
Max torque 280 Nm

CODICE / CODE	U
PER FLANGIA / FOR FLANGE	I 4

BOCCHIE DI ASPIRAZIONE E MANDATA
INLET AND OUTLET PORTS

XX STANDARD

XX SU ORDINAZIONE / *ON DEMAND*

NON DISPONIBILI / *NOT AVAILABLE*

	X	Y	Z
A	19	40	M8 18
B	27	51	M10 18
C	33	62	M12 18

		OUT		
		A	B	C
IN	A	49		
	B	48	46	
	C		47	45

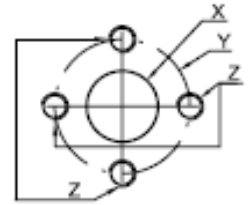

	X	Y	Z
A	20	40	M6 12
B	27	55	M8 18

		OUT	
		A	B
IN	A	50	
	B	51	52

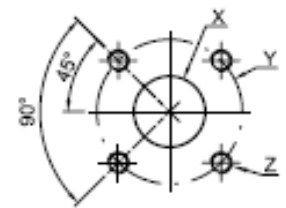

	X	Y	Z	J
A	12.5	38.1	17.5	5/16-18UNC-2B
B	19	47.6	22.2	3/8-16UNC-2B
C	25.4	52.4	26.2	
D	30.5	58.7	30.2	7/16-14UNC-2B
E	39.3	69.8	35.7	1/2-13UNC-2B
F	51	77.8	42.9	

		OUT					
		A	B	C	D	E	F
IN	A	53					
	B	54	55				
	C		56	57			
	D			58	59		
	E				60	61	
	F					62	63

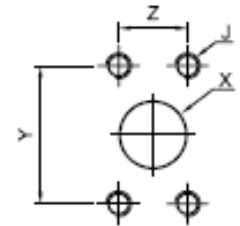

Disponibile solo con corpo WL
 Available only with WL body

	X	Y	Z	DIMENSIONE NOMINALE
A	1" G	22	27	1
B	1" 1/4 G	22	33	1-1/4
C	1" 1/2 G	24	38	1-1/2

		OUT		
		A	B	C
IN	A	64		
	B	65	66	
	C		67	68

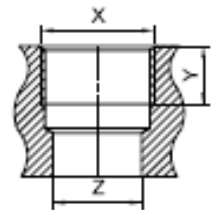

	DIMENSIONE NOMINALE	X	Y	Z	J
A	3/4"	1-1/16-12UN-2B	42	0.5	24.5
B	1"	1-5/16-12UN-2B	49	0.5	30.5
C	1"-1/4	15/8-12UN-2B	58	0.5	39
D	1"-1/2	1-7/8-12UN-2B	65	0.5	45

		OUT			
		A	B	C	D
IN	A	69			
	B	70	71		
	C		72	73	
	D			74	75

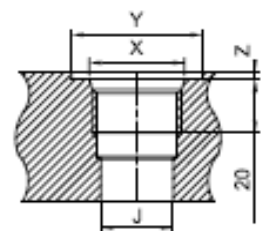

SUPPORTI INTEGRATI INBOARD BEARINGS

TIPO 1 - TYPE 1

Supporto integrato con cuscinetto singolo

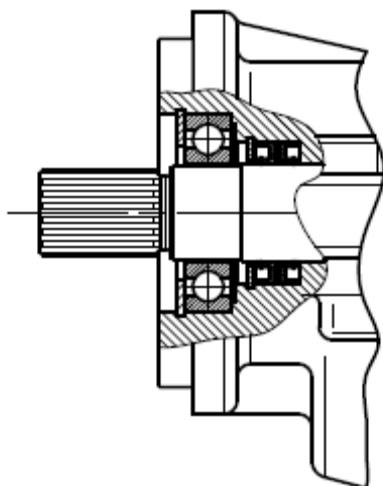

Versione adatta per impieghi con limitati carichi radiali e in assenza di carichi assiali

Application made to support radial load and without axial

Disponibile per flange B3 - L3 - G6 - E6.
Available for flanges type B3 - L3 - G6 - E6.

Disponibile per alberi B - L - D - S - K - P - H.

TIPO 2 - TYPE 2

Supporto integrato con doppio cuscinetto a rulli conici

Integrated bearing support with double taper roller bearings

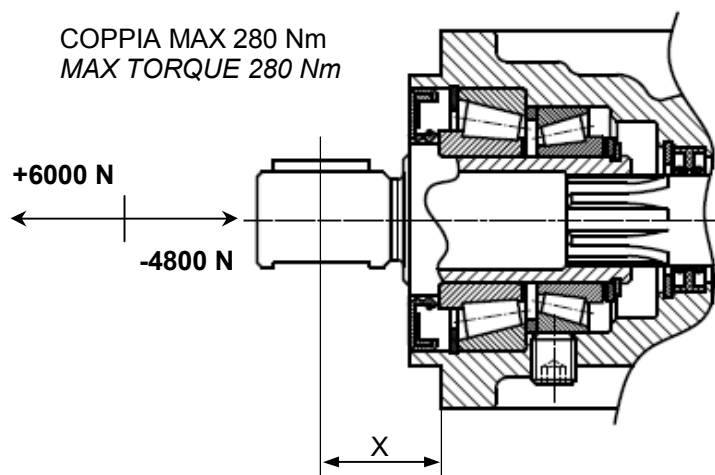

Versione adatta per impieghi con carichi radiali e assiali

Application made to support axial and radial load.

Disponibile per flangia I4
Available for flange type I4

Disponibile per alberi S - K - P - H - M - R.
Available for shafts type S - K - P - H - M - R.

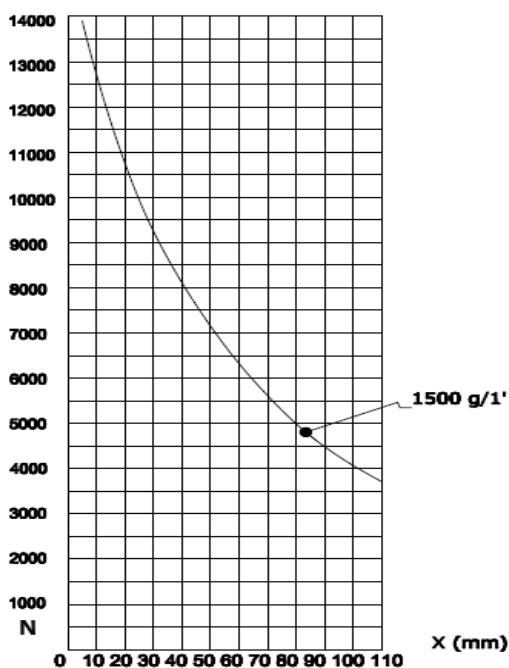

DATI DI BASE PER STESURA GRAFICO

- Durata a fatica corretta 1000 h
- Grasso VG 100
- Temperatura 70°C
- Affidabilità 90%
- Grado di contaminazione medio 60μ

IL VALORE DEI CARICHI É INFLUENZATO DALLE CONDIZIONI DI FUNZIONAMENTO.

LOAD DIAGRAM

- Rating fatigue life 1000 h
- Grease type VG-46
- Temperature 70°C
- Trust 90%
- Contamination 60 μ

1 LOAD VALUE IS DUE TO WORKING CONDITIONS

Rev. 03.16

ISTRUZIONI PER ORDINARE UNITÁ SINGOLE W3
HOW TO ORDER W3 SINGLE UNIT

1 2 3 4 5 6 7 8 9 10 11 12 13

03	0	W0	M	A	55	C	0	48	X	S	1	B	VR	75
-----------	----------	-----------	----------	----------	-----------	----------	----------	-----------	----------	----------	----------	----------	-----------	-----------

1	RASAMENTI / BUSHING BLOCK	CODICE / CODE
	ALLUMINIO / ALLOY	2
	BRONZO / BRONZE	0

2	TIPO DI UNITÁ / UNIT TYPE	CODICE / CODE
	POMPA / PUMP	-
	MOTORE / MOTOR	M

3 - 6	FLANGIA / FLANGE (PAG. 10 - 11)	CODICE / CODE
	EUROPEA GR. 3 / EUROPEAN GR. 3	A - 0
	ITALIANA / ITALIAN	N - 7
	AMERICANA SAE B / AMERICAN SAE B	B - 3
	ISO / ISO	I - 4
	EUROPEA GR. 3,5 / EUROPEAN GR. 3,5	D - 5
	AMERICANA SAE C / AMERICAN SAE C	C - 6
	AMERICANA SAE C / AMERICAN SAE C	E - 6
	ITALIANA / ITALIAN	N - 8
	AMERICANA SAE B / AMERICAN SAE B	L - 3

4	CILINDRATA / CAPACITY cm ³	CODICE / CODE
	15.5	15
	19.9	20
	24.9	25
	29.9	30
	34.3	35
	40.5	40
	45.2	45
	49.9	50
	54.5	55
	60	60
	63.9	64
	70	70
	78.7	80
	89.6	90

5	ALBERO / SHAFT (PAG. 12-13-14)	CODICE / CODE
	CONICO 1:8 / TAPERED 1:8	C
	CONICO 1:5 / TAPERED 1:5	A
	ANSI B92.1 13TH 16/32 DP	B
	CILINDRICO Ø22.22 / STRAIGHT Ø22.22	L
	CILINDRICO Ø22 / STRAIGHT Ø22	Q
	CILINDRICO Ø25.4 / STRAIGHT Ø25.4	D
	CONICO 1:8 / TAPERED 1:8	E
	ANSI B92.1 15TH 16/32 DP	S
	ISO 14 8x32x36	H
	CILINDRICO Ø22 / STRAIGHT Ø22	N

	CILINDRICO Ø30 / STRAIGHT Ø30	G
	ANSI B92.1 14TH 12/24 DP	K
	CILINDRICO Ø31.7 / STRAIGHT Ø31.7	P
	UNI 8953 6x21x25	F
	1" 3/8 DIN 9611 MASCHIO / MALE	M
	1" 3/8 DIN 9611 FEMMINA / FEMALE	R
	1" 3/8 DIN 9611 - Z21 FEMMINA / FEMALE	U

7	BOCCE / PORTS	CODICE / CODE
	VEDI TABELLA PAG. 16 / SEE TABLE AT PAGE 16	

8	POSIZIONE BOCCE / PORTS POSITION	CODICE / CODE
	LATERALE / LATERAL	X
	POSTERIORE / REAR	J

9	ROTAZIONE / ROTATION	CODICE / CODE
	DESTRO / RIGHT	D
	SINISTRO / LEFT	S
	BIDIRECTIONAL WITH INTERNAL DRAIN	Y
	BIDIRECTIONAL WITH EXTERNAL DRAIN	R
	BIDIRECTIONAL WITH LATERAL DRAIN	R1

10	SUPPORTI / SUPPORT (PAG. 17)	CODICE / CODE
	SENZA / WITHOUT	0
	TIPO 1 / TYPE 1	1
	TIPO 2 / TYPE 2	2

11	PARAOILIO / SHAFT SEAL (PAG. 7)	CODICE / CODE
	STANDARD / STANDARD	N
	STANDARD FKM / STANDARD FKM	V
	STANDARD HNBR / STANDARD HNBR	H
	5 BAR NBR / 5 BAR NBR	R
	5 BAR FKM / 5 BAR FKM	RV
	5 BAR HNBR / 5 BAR HNBR	RH
	DOPPIO MIM NBR / DOUBLE SEAL NBR	N2
	DOPPIO MIM FKM / DOUBLE SEAL FKM	V2
	VARISEAL NBR / VARISEAL NBR	B
	25 BAR NBR / 25 BAR NBR	BN
	25 BAR FKM / 25 BAR FKM	BV

12	VALVOLA DI MASSIMA / RELIEF VALVE	CODICE / CODE
	SENZA / WITHOUT	-
	TARATURA REGOLABILE / ADJUST. CALIBRATION	VR
	TARATURA FISSA / FIXED CALIBRATION	VF

13	VALORI TARATURA VALVOLA / VALVE CALIBRATION	CODICE / CODE
	50 - 75 - 100 - 125 - 150 - 200 - 250 - 300 - 330	75

KIT DI MONTAGGIO POMPE MULTIPLE W3
ASSEMBLING KIT FOR MULTIPLE PUMPS W3

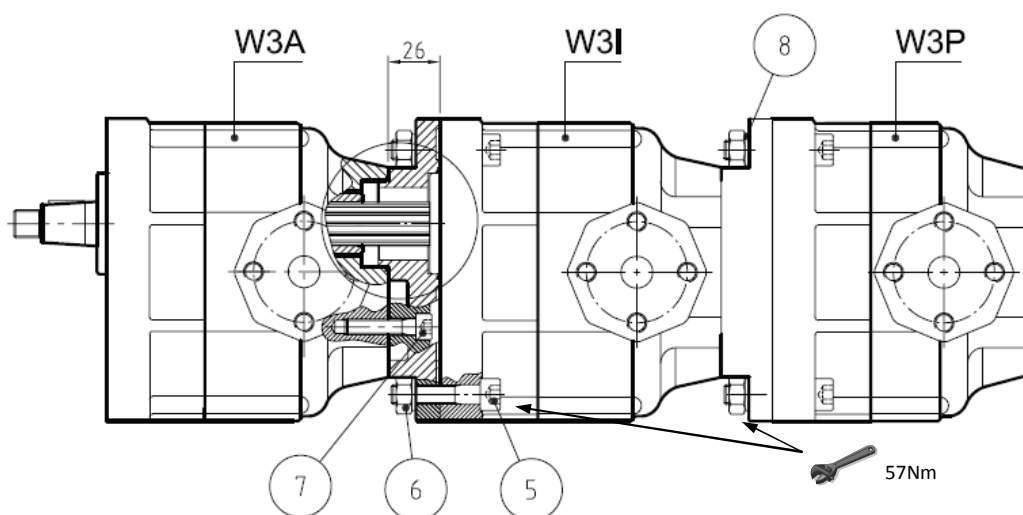
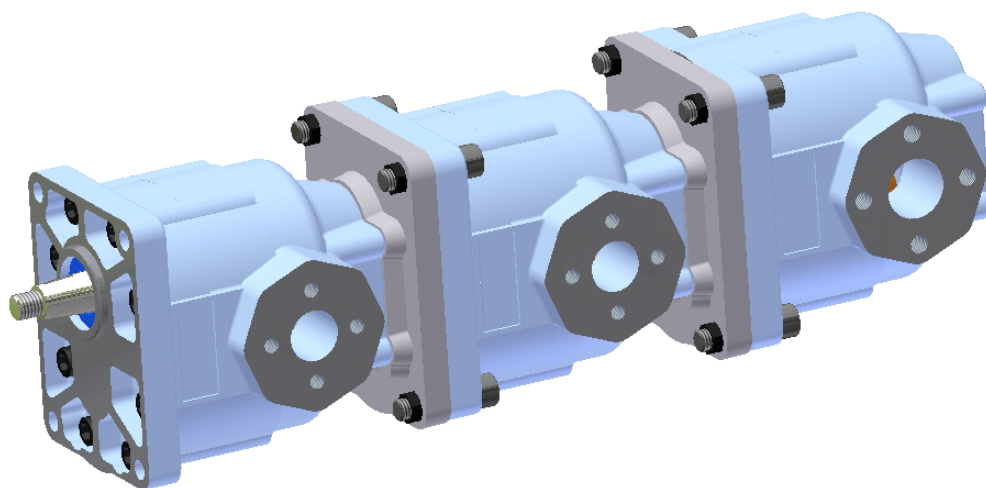

KIT DI MONTAGGIO
ASSEMBLING KIT

Cod. K300028

Ref	PARTI PARTS
1	OR 3200 / O-Ring 3200
2	OR 2162 / O-Ring 2162
3	Piastra di collegamento / Connection plate
4	Mozzo DIN 5482 / Coupling DIN 5482
5	TCE M10x55 UNI 5931 / TCE M10x55 UNI 5931
6	Dado M10 / Stud nut M10
7	TCE M8x25 UNI 5931 / TCE M8x25 UNI 5931
8	Rondella 10.5x16x2 / Washer 10.5x16x2

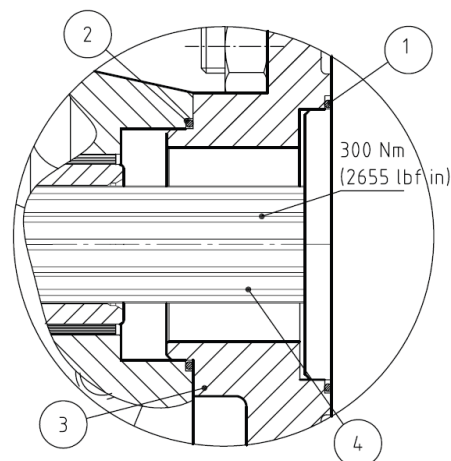

ISTRUZIONI PER ORDINARE POMPE MULTIPLE W3
HOW TO ORDER W3 MULTIPLE PUMPS

1	2	3	4	5	6	7	8	9					
03	0	W0	A	A	55	C	0	48	X	S	1	B	FRONT PUMP
1	3	6	7										
03	0	W0	I	A	55	0	0	48	X	S	0		MIDDLE PUMP
1	3	6	7										
03	0	W0	P	A	55	0	0	48	X	S	0		REAR PUMP

1	RASAMENTI / BUSHING BLOCK	CODICE / CODE
	ALLUMINIO / ALLOY	2
	BRONZO / BRONZE	0

2 - 5	FLANGIA / FLANGE (PAG. 10 - 11)	CODICE / CODE
	EUROPEA GR. 3 / EUROPEAN GR. 3	A - 1
	ITALIANA / ITALIAN	N - 7
	AMERICANA SAE B / AMERICAN SAE B	B - 3
	ISO / ISO	I - 4
	EUROPEA GR. 3,5 / EUROPEAN GR. 3,5	D - 5
	AMERICANA SAE C / AMERICAN SAE C	C - 6
	AMERICANA SAE C / AMERICAN SAE C	E - 6
	ITALIANA / ITALIAN	N - 8
	AMERICANA SAE B / AMERICAN SAE B	L - 3

3	CILINDRATA / CAPACITY cm ³	CODICE / CODE
	15.5	15
	19.9	20
	24.9	25
	29.9	30
	34.3	35
	40.5	40
	45.2	45
	49.9	50
	54.5	55
	60	60
	63.9	64
	70	70
	78.7	80
	89.6	90

4	ALBERO / SHAFT (PAG. 12-13-14)	CODICE / CODE
	CONICO 1:8 / TAPERED 1:8	C
	CONICO 1:5 / TAPERED 1:5	A
	ANSI B92.1 13TH 16/32 DP	B
	CILINDRICO Ø22.22 / STRAIGHT Ø22.22	L
	CILINDRICO Ø22 / STRAIGHT Ø22	Q

	CILINDRICO Ø25.4 / STRAIGHT Ø25.4	D
	CONICO 1:8 / TAPERED 1:8	E
	ANSI B92.1 15TH 16/32 DP	S
	ISO 14 8x32x36	H
	CILINDRICO Ø22 / STRAIGHT Ø22	N
	CILINDRICO Ø30 / STRAIGHT Ø30	G
	ANSI B92.1 14TH 12/24 DP	K
	CILINDRICO Ø31.7 / STRAIGHT Ø31.7	P
	UNI 8953 6x21x25	F
	1" 3/8 DIN 9611 MASCHIO / MALE	M
	1" 3/8 DIN 9611 FEMMINA / FEMALE	R
	1" 3/8 DIN 9611 - Z21 FEMMINA / FEMALE	U

6	BOCCHE / PORTS	CODICE / CODE
	VEDI TABELLA PAG. 16 / SEE TABLE AT PAGE 16	

7	ROTAZIONE / ROTATION	CODICE / CODE
	DESTRO / RIGHT	D
	SINISTRO / LEFT	S

8	SUPPORTI / SUPPORT (PAG. 17)	CODICE / CODE
	SENZA / WITHOUT	0
	TIPO 1 / TYPE 1	1
	TIPO 2 / TYPE 2	2

9	PARAOILIO / SHAFT SEAL (PAG. 7)	CODICE / CODE
	STANDARD / STANDARD	N
	STANDARD FKM / STANDARD FKM	V
	STANDARD HNBR / STANDARD HNBR	H
	5 BAR NBR / 5 BAR NBR	R
	5 BAR FKM / 5 BAR FKM	RV
	5 BAR HNBR / 5 BAR HNBR	RH
	DOPPIO MIM NBR / DOUBLE SEAL NBR	N2
	DOPPIO MIM FKM / DOUBLE SEAL FKM	V2
	VARISEAL NBR / VARISEAL NBR	B
	25 BAR NBR / 25 BAR NBR	BN
	25 BAR FKM / 25 BAR FKM	BV

KIT DI MONTAGGIO POMPE MULTIPLE W3 - Z2
ASSEMBLING KIT FOR MULTIPLE PUMPS W3 - Z2

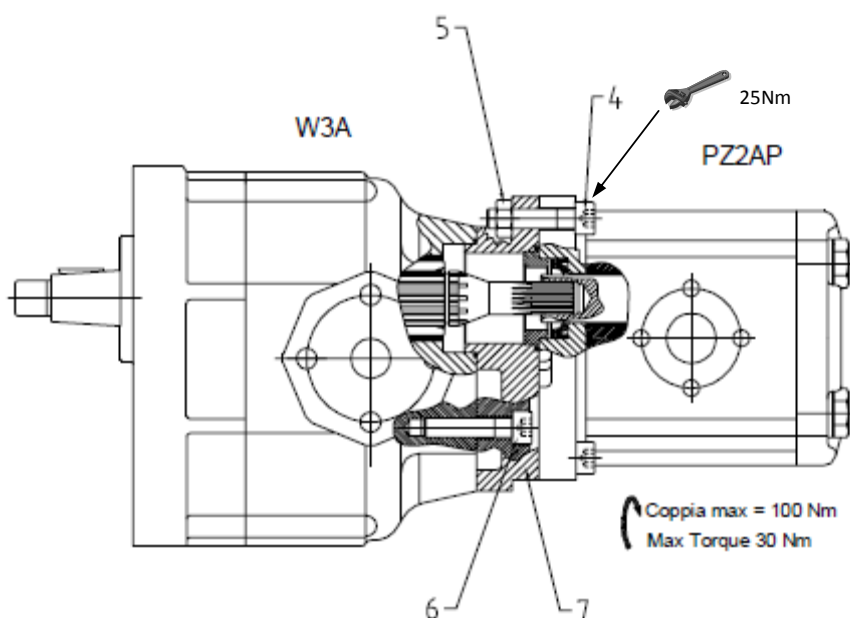
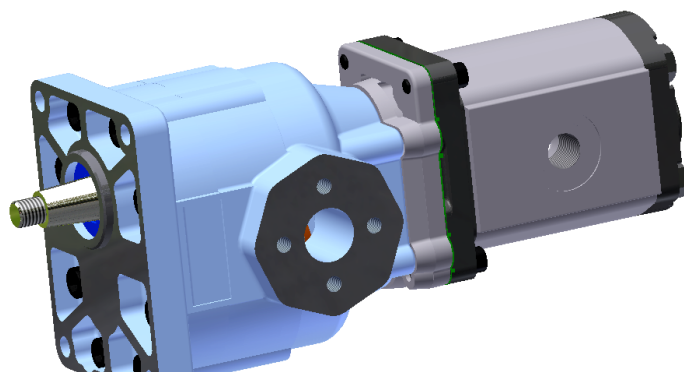

KIT DI MONTAGGIO
ASSEMBLING KIT

W3 + 02ZA

cod. K3000038

Ref	PARTI PARTS
1	OR 2150 / O-Ring 2150
2	OR 2162 / O-Ring 2162
3	Mozzo 25x21/Z=25 / Coupling 25x21/Z=25
4	TCE M8x35 UNI 5931 / TCE M8x35 UNI 5931
5	Dado M8 / Stud nut M8
6	TCE M8x35 UNI 5931 / TCE M8x35 UNI 5931
7	Piastra di collegamento / Connection plate
8	Bussola di centraggio / Pilot ring

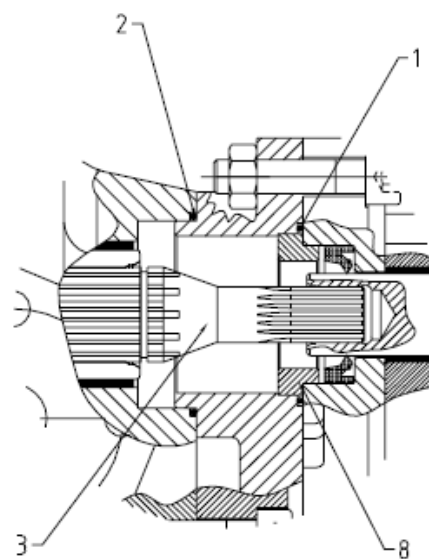

KIT DI MONTAGGIO POMPE MULTIPLE W3 - Z1
ASSEMBLING KIT FOR MULTIPLE PUMPS W3 - Z1

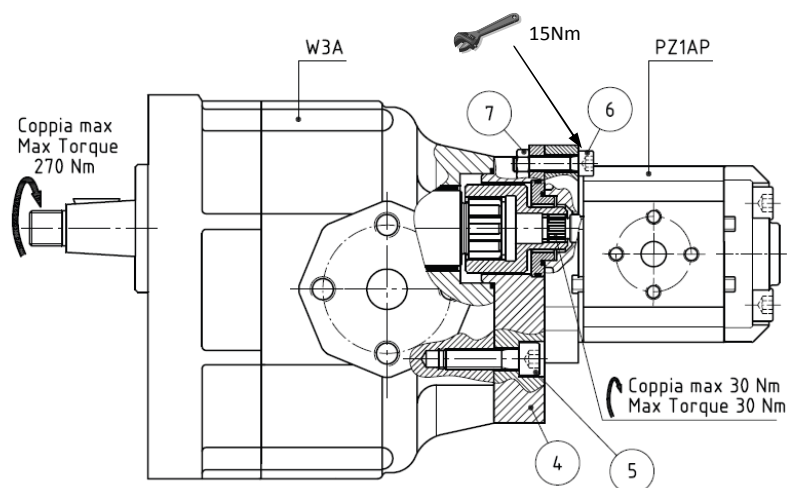
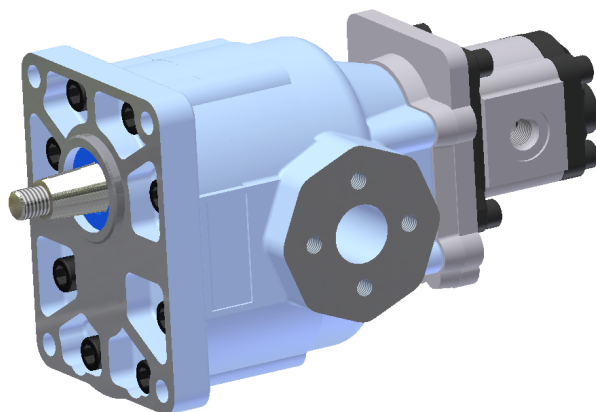

KIT DI MONTAGGIO
ASSEMBLING KIT

cod. K3000043

Ref	PARTI PARTS
1	OR 2100 / O-Ring 2100
2	OR 2162 / O-Ring 2162
3	Mozzo 25x21-12x19 / Coupling 25x21-12/19
4	Piastra di collegamento / Connection plate
5	TCE M8x30 UNI 5931 / TCE M8x30 UNI 5931
6	TCE M6x25 UNI 5931 / TCE M6x25 UNI 5931
7	Dado M6 / Stud nut M6
8	OR 2137 / O-Ring 2137
9	Bussola di centraggio / Pilot ring

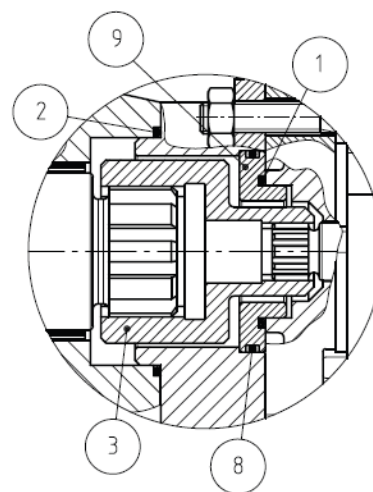

DIMENSIONI POMPE MULTIPLE W3L
OVERALL DIMENSIONS MULTIPLE PUMPS W3L

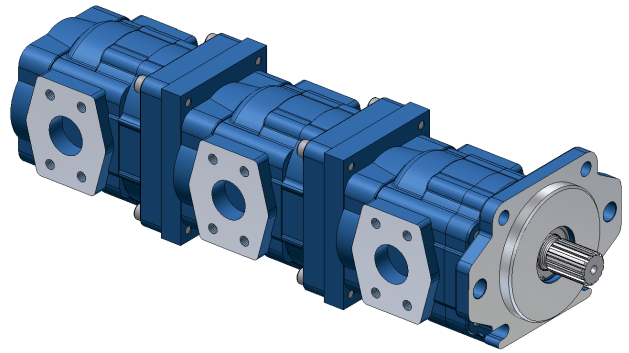

COPPIA MAX 300 Nm
 MAX TORQUE 300 Nm

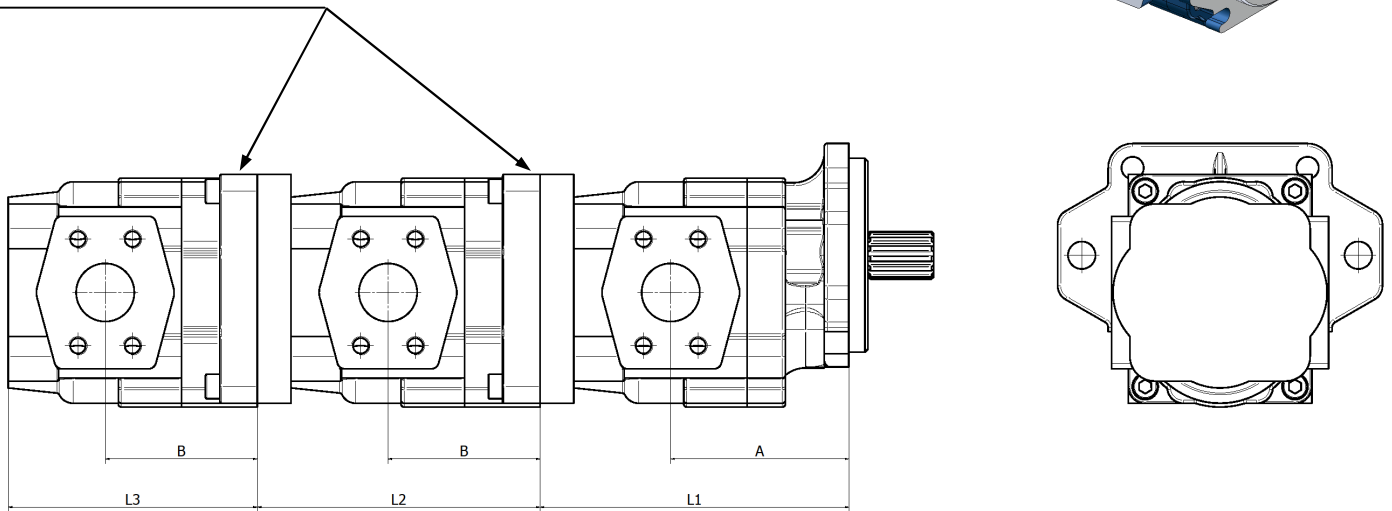

Tipo - Type		20	25	30	35	40	45	50	55	60	64	70	80	90
A	mm	104	107	110	113	108	111	114	117	105	107	111	117	117
B	mm	87	90	93	96	91	94	97	100	88	90	94	100	100
L1	mm	159	162	165	168	172	175	178	181	185	187	191	197	202
L2	mm	142	145	148	151	155	158	161	164	168	170	174	180	185
L3	mm	126	129	132	135	139	142	145	148	152	154	158	164	164

KIT DI MONTAGGIO
ASSEMBLING KIT Cod. K3000041

Ref	PARTI PARTS
1	Bussola / Center ring
2	Mozzo DIN 5482 / Coupling DIN 5482
3	OR 2162 / O-Ring 2162
4	OR 3200 / O-Ring 3200
5	TCE M8x30 UNI 5931 / TCE M8x30 UNI 5931
6	TCE M10x45 UNI 5931 / TCE M10x45 UNI 5931
7	Piastra di collegamento / Connection plate

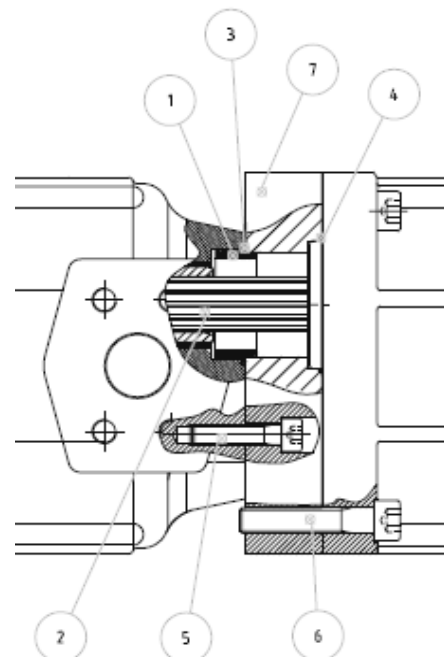

DIMENSIONI POMPE MULTIPLE COMPATTE W3L CON ASPIRAZIONE COMUNE
OVERALL DIMENSIONS MULTIPLE PUMPS W3L WITH COMMON INLET - "COMPACT"

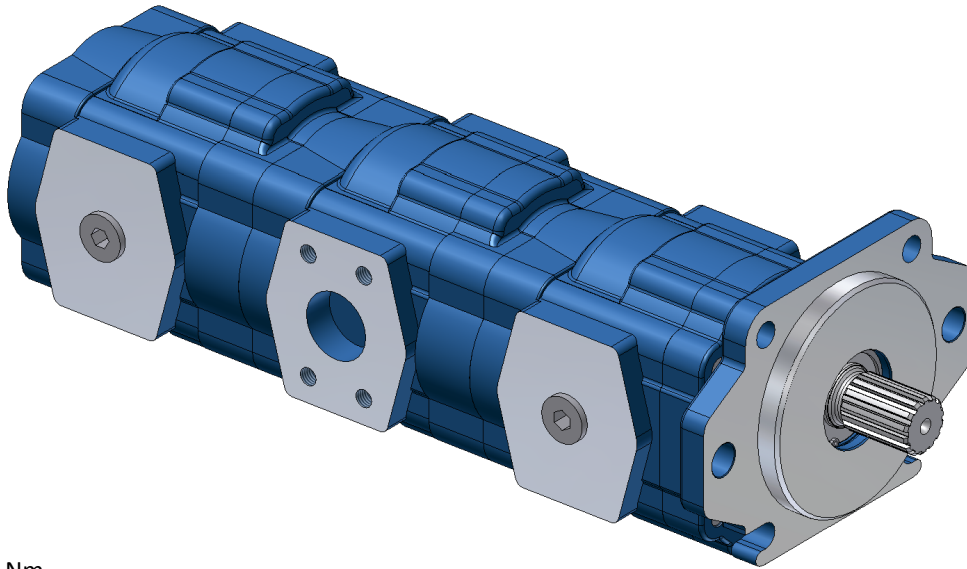

COPPIA MAX 300 Nm
 MAX TORQUE 300 Nm

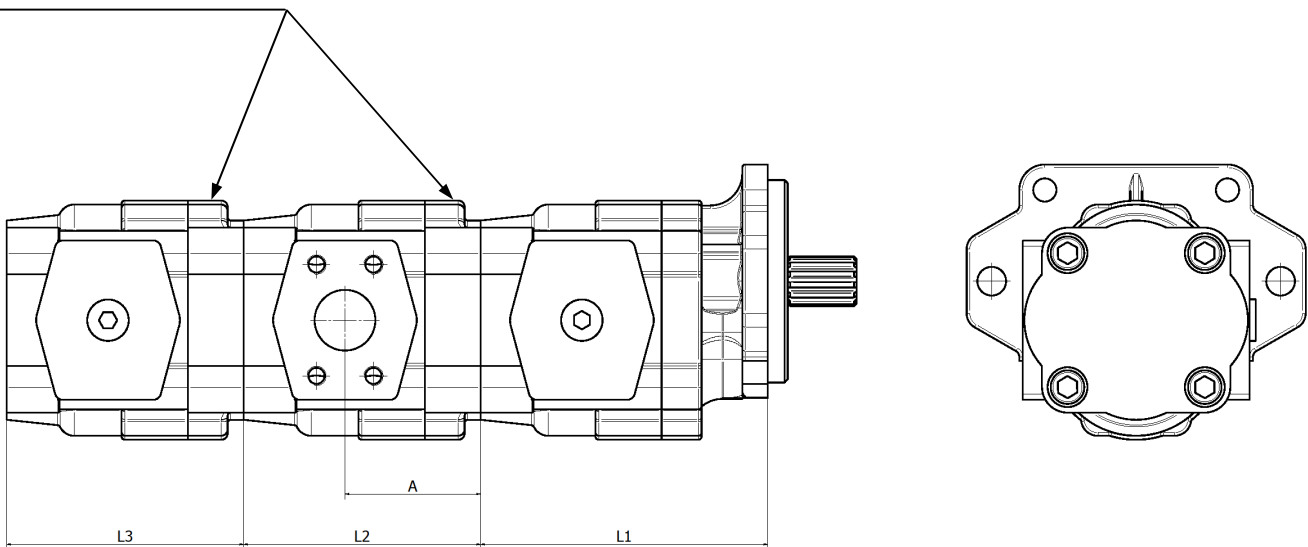

Tipo - Type		20	25	30	35	40	45	50	55	60	64	70	80	90
A	mm	72	75	78	81	76	79	82	85	73	75	79	85	85
L1	mm	137	140	143	146	150	153	156	159	163	165	169	175	180
L2	mm	106	109	112	115	119	122	125	128	132	134	138	144	149
L3	mm	111	114	117	120	124	127	130	133	137	139	143	149	149

Per maggiori informazioni, contattare il nostro ufficio tecnico.
 For more info, please contact our technical office.

ISTRUZIONI PER L'ORDINAZIONE DI POMPE MULTIPLE WL3

HOW TO ORDER WL3 MULTIPLE PUMPS

	1		2	3	3	3	4	5	6	6	6	7	8	9
03	0	WL	A	20*	20*	20*	E	0	70*	70*	70*	D	0	N

ESEMPIO PER POMPA A TRE STADI
 EXEMPLE FOR A PUMP WITH THREE STAGES

1	RASAMENTI / BUSHING BLOCK	CODICE / CODE
	ALLUMINIO / ALLOY	2
	BRONZO / BRONZE	0

2 - 5	FLANGIA / FLANGE (PAG. 10-11)	CODICE / CODE
	AMERICANA SAE B / AMERICAN SAE B	B - 3
	ISO / ISO	I - 4
	EUROPEA GR. 3,5 / EUROPEAN GR. 3,5	D - 5
	AMERICANA SAE C / AMERICAN SAE C	C - 6
	AMERICANA SAE C / AMERICAN SAE C	E - 6
	AMERICANA SAE B / AMERICAN SAE B	L - 3

3	CILINDRATA / CAPACITY cm ³	CODICE / CODE
	19.9	20
	24.9	25
	29.9	30
	34.3	35
	40.5	40
	45.2	45
	49.9	50
	54.5	55
	60	60
	63.9	64
	70	70
	78.7	80
	89.6	90

4	ALBERO / SHAFT (PAG. 12-13-14)	CODICE / CODE
	ANSI B92.1 13TH 16/32 DP	B
	CILINDRICO Ø22.22 / STRAIGHT Ø22.22	L
	CILINDRICO Ø25.4 / STRAIGHT Ø25.4	D
	CONICO 1:8 / TAPERED 1:8	E
	ANSI B92.1 15TH 16/32 DP	S
	ISO 14 8x32x36	H

	CILINDRICO Ø30 / STRAIGHT Ø30	G
	ANSI B92.1 14TH 12/24 DP	K
	CILINDRICO Ø31.7 / STRAIGHT Ø31.7	P
	UNI 8953 6x21x25	F

6	BOCCHE / PORTS	CODICE / CODE
	VEDI TABELLA PAG. 16 / SEE TABLE AT PAGE 16	

7	ROTAZIONE / ROTATION	CODICE / CODE
	DESTRO / RIGHT	D
	SINISTRO / LEFT	S

8	SUPPORTI / SUPPORT (PAG. 17)	CODICE / CODE
	SENZA / WITHOUT	0
	TIPO 1 / TYPE 1	1

9	PARAOILIO / SHAFT SEAL (PAG. 7)	CODICE / CODE
	STANDARD / STANDARD	N
	STANDARD FKM / STANDARD FKM	V
	STANDARD HNBR / STANDARD HNBR	H
	5 BAR NBR / 5 BAR NBR	R
	5 BAR FKM / 5 BAR FKM	RV
	5 BAR HNBR / 5 BAR HNBR	RH
	DOPPIO MIM NBR / DOUBLE SEAL NBR	N2
	DOPPIO MIM FKM / DOUBLE SEAL FKM	V2
	VARISEAL NBR / VARISEAL NBR	B
	25 BAR NBR / 25 BAR NBR	BN
	25 BAR FKM / 25 BAR FKM	BV

* INSERIRE NEL CODICE IL VALORE PER LA POMPA DESIDERATA
 INSERT IN THE CODE THE VALUE FOR THE DESIRED PUMP

Ronzio Oleodinamica si riserva di apportare in qualunque momento modifiche ai modelli descritti sia per ragioni di natura tecnica che commerciale. Riproduzione vietata.

Ronzio Oleodinamica reserves the right to make change to the product described here in any time it deems fit in relation to technical or commercial requirements.



VIALE INDUSTRIA 37/39, 20010 BOFFALORA TICINO -MI- ITALY
TEL. +39 02 9754057 FAX +39 02 97255070
E-mail sales@ronzio.com - www.ronzio.com