

# Series TAP 50

Nylon oil filler and air breather filler caps

## Dimensions

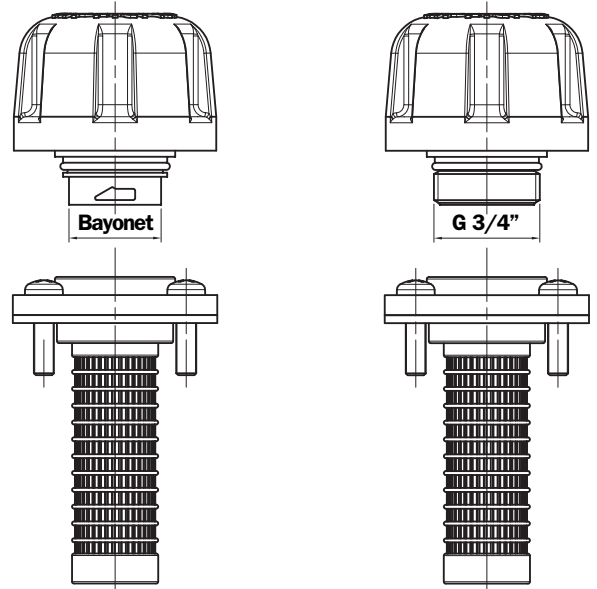
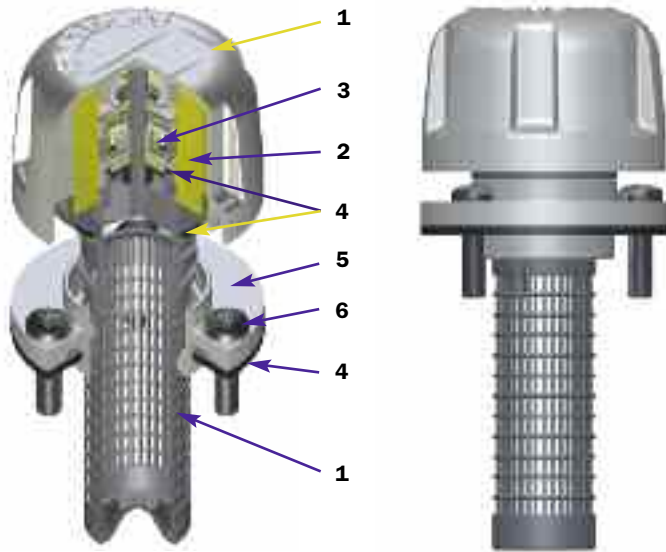

### TAP50 (Materials)

- 1 - Cover/ringnut: Nylon
- 2 - Filter element: Impregnated paper  
Polyurethane
- 3 - Pressurisation valve: Nylon  
Galvanised Steel  
NBR
- 4 - Seal: NBR
- 5 - Flange: Nylon
- 6 - Screws: Galvanised Steel
- 7 - Basket: Nylon

### Flow rates with $\Delta p$ : 0,02 bar

Filtration	l/min
10 $\mu$ m	202

### Quantity per pack Number of Parts

TAP50	10
-------	----

### Weight

TAP50: 0,060 kg

### Reservoir holes

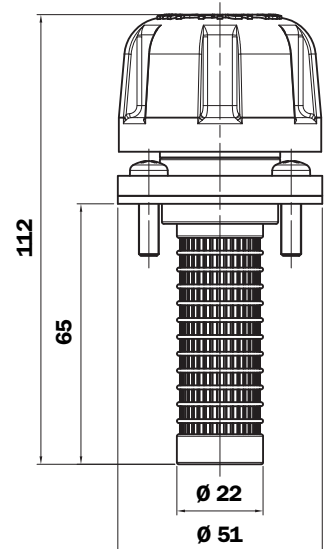
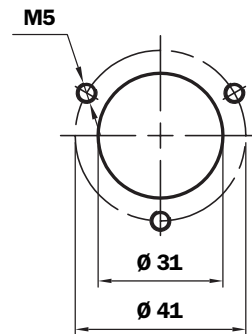

## Ordering information

### Filler cap

TAP50

Example: TAP50 B 10 A 0 1 P01

### 1 - Connection to reservoir

- B** Flange with bayonet connection
- C** Flange with bayonet connection G 3/4"

### 2 - Filter element

- 03** 3  $\mu$ m - Impregnated paper
- 10** 10  $\mu$ m - Polyurethane

### 3 - Seal

- A** NBR

### 4 - Valves

- 0** Without
- 1** 0,5 bar pressurisation valve

### 5 - Basket

- 1** L= 65 mm

### 6 - Options

- P01** MP Filtri standard