

MAFITRI
 filtri per oleodinamica
 Via Matteotti 2
 20060 Pessano con Bornago (Mi)
 Tel. 02-95703.1
 Fax 02-95741497 / 95740188

**PRESSURE GAUGE BY-PASS
 VALVE & MULTI-POINT
 SELECTOR FOR PRESSURE
 GAUGES**

Rev. 03

Date: 21/03/01

The purpose of these by-pass valves is to protect the pressure gauges. When reading is not required, the gauges are directly connected to the oil tank extending their working life. For the EM series three mounting versions are foreseen (A= panel, with hexagonal nut, B= panel, with screws, C= universal). The multi-point selectors have the opportunity to connect 1 to 6 manometers, thanks to several pipe taps available on it.

Both these products are manufactured with push or rotary bottom options.

EM1-A -G 50A

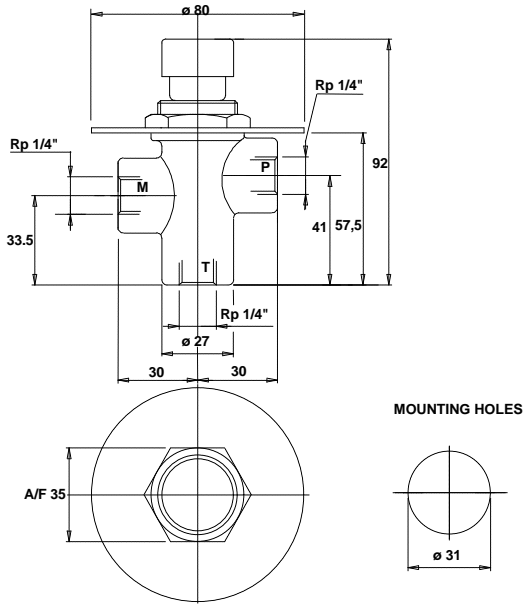

EM1-B -G 50A

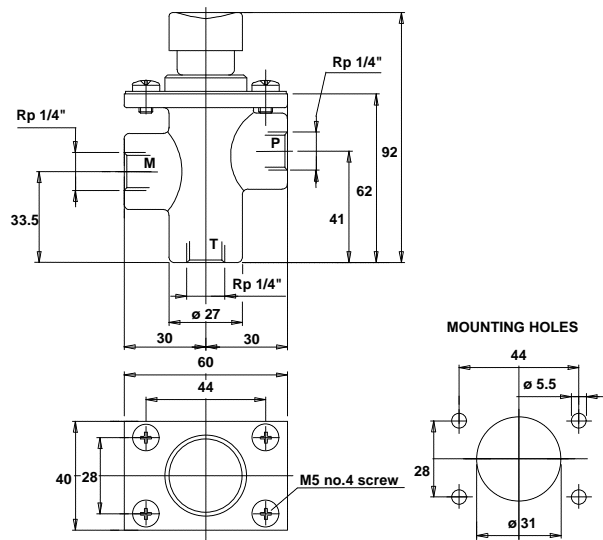

EM1-C -G 50A

