

# Vane pumps type PFE-31, PFE-41, PFE-51

fixed displacement - cartridge design

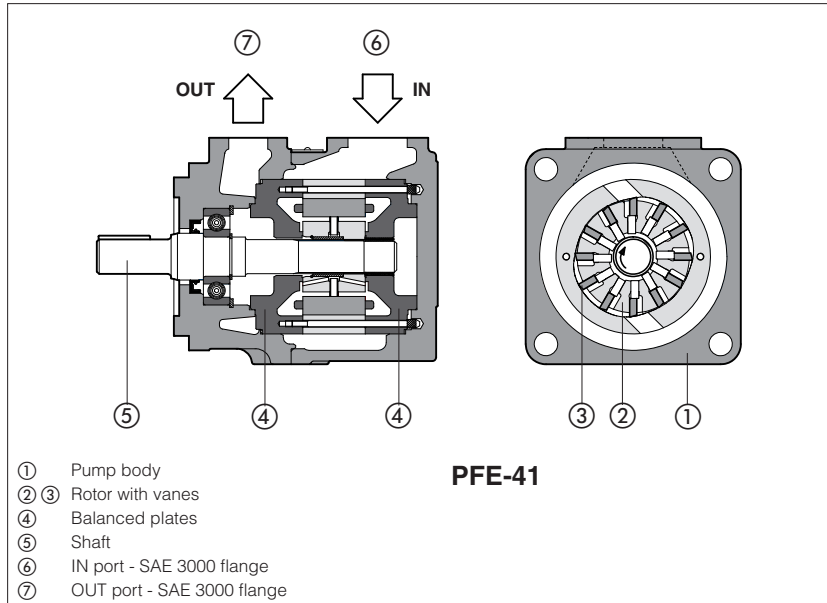

**PFE-\*1** are fixed displacement vane pumps, (2) (3) cartridge design with integral hydraulic balancing (4) for high volumetric efficiency, long service life and low noise level.

They are available in three different body sizes with max displacements up to 44, 85 and 150 cm<sup>3</sup>/rev and single, multiple or with through-shaft configurations.

Mounting flange according to SAE J744 standard.

Inlet and outlet ports can be oriented in four different positions to match any installation requirement.

Simplified maintenance as the pumping cartridge can be easily replaced.

Max displacement: **up to 150 cm<sup>3</sup>/rev**  
Max pressure: **210 bar**

## 1 MODEL CODE OF SINGLE PUMPS

<b>PFE</b>	<b>XA</b>	-	<b>31</b>	<b>036</b>	/	<b>1</b>	<b>D</b>	<b>T</b>	*	/	*
Fixed displacement vane pump											
<p><b>Option for pumps with through shaft</b>, see section 3:</p> <p><b>XA, XA7, XB, XB7, XC</b> = for coupling with other pumps type PFE  <b>XO</b> = with through shaft, without rear flange</p> <p><b>Size</b>, see section 2:  <b>31, 41, 51</b></p> <p><b>Displacement (cm<sup>3</sup>/rev)</b>, see section 2</p> <p><b>Drive shaft</b>, see section 8 and 9:                  cylindrical, keyed  <b>1</b> = standard  <b>2</b> = long version - only for PFE-41 and PFE-51  <b>3</b> = for high torque applications                  splined:  <b>5</b> = for single and multiple pumps (any position)  <b>6</b> = for single and multiple pumps (only first position)  <b>7</b> = for second and third position in multiple pumps } only for PFE-31 and PFE-41</p> <p><b>Note:</b> for multiple pumps factory assembled, see tech. table A190</p>											
<p><b>Seals material:</b>                  - = NBR  <b>PE</b> = FKM</p> <p>Series number</p> <p><b>Port orientation</b>, see section 6:  <b>T</b> = standard  <b>U, V, W</b> = on request</p> <p><b>Direction of rotation</b>, viewed from the shaft end:  <b>D</b> = clockwise (supplied standard if not otherwise specified)  <b>S</b> = counterclockwise</p>											

## 2 HYDRAULIC CHARACTERISTICS - based on mineral oil ISO VG 46 at 50 °C

Size code	31						41						51			
	010	016	022	028	036	044	029	037	045	056	070	085	090	110	129	150
Displacement (cm <sup>3</sup> /rev)	10.5	16.5	21.6	28.1	35.6	43.7	29.3	36.6	45.0	55.8	69.9	85.3	90.0	109.6	129.2	150.2
Max working pressure (1) (bar)	160															
Recommended pressure on inlet port	from -0,15 to 1,5 bar for speed up to 1800 rpm; from 0 to +1,5 bar for speed over 1800 rpm															
Min speed (rpm)	800															
Max speed (2) (rpm)	2400	2800	2800	2800	2800	2500	2500	2500	2500	2500	2500	2000	2200	2200	2200	1800
Volumetric efficiency (3)	80	83	87	90	90	92	90	92	93	93	93	94	93	93	93	94
Noise level (3) (dBA)	62	62	63	63	63	64	67	67	68	68	69	69	72	72	73	74

- (1) Max pressure is 160 bar for HFUD, HFDR and HFC fluids  
 (2) Max speed is 1800 rpm for /PE versions; 1500 rpm for HFUD, HFDR and HFC fluids  
 (3) Measuring data with: n = 1450 rpm; P = 140 bar;

### 3 OPTION FOR PUMPS WITH THROUGH SHAFT

Pump size	PFE-31		PFE-41			PFE-51				
Through shaft option type	XA	XA	XB	XA7	XB7	XA	XB	XC	XA7	XB7
Splined coupling characteristics	SAE 16/32-9T	SAE 16/32-9T	SAE 16/32-13T	SAE 16/32-13T	SAE 12/24-14T	SAE 16/32-14T	SAE 13/32-13T	SAE 12/24-14T	SAE 16/32-13T	SAE 12/24-14T
2 <sup>nd</sup> pump	PFE-3* shaft type 5	PFE-3* shaft type 5	PFE-4* shaft type 5	PFE-3* shaft type 7	PFE-4* shaft type 7	PFE-3* shaft type 5	PFE-4* shaft type 5	PFE-5* shaft type 5	PFE-3* shaft type 7	PFE-4* shaft type 7

### 4 GENERAL CHARACTERISTICS

Assembly position	Any position.
Loads on the shaft	Axial and radial loads are not allowed on the shaft. The coupling should be sized to absorb the power peak.
Ambient temperature range	-20°C ÷ +80°C
Compliance	REACH Regulation (EC) n°1907/2006 RoHS Directive 2011/65/EU as last update by 2015/863/EU

### 5 SEALS AND HYDRAULIC FLUIDS - for other fluids not included in below table, consult our technical office

Seals, recommended fluid temperature	NBR seals (standard) = -25°C ÷ +60°C, with HFC hydraulic fluids = -20°C ÷ +50°C FKM seals (/PE option) = -20°C ÷ +80°C		
Recommended viscosity	10÷100 mm <sup>2</sup> /s - max at cold start 800 mm <sup>2</sup> /s		
Max fluid contamination level	normal operation	ISO4406 class 21/19/16 NAS1638 class 10	see also filter section at www.atos.com or KTF catalog
	longer life	ISO4406 class 18/16/13 NAS1638 class 8	
Hydraulic fluid	Suitable seals type	Classification	Ref. Standard
Mineral oils	NBR, FKM	HL, HLP, HLPD, HVLP, HVLPD	DIN 51524
Flame resistant without water	FKM	HFDU, HFDR (1)	ISO 12922
Flame resistant with water	NBR	HFC (1)	

(1) See performance restrictions at section 2

### 6 PORT ORIENTATION

Single pumps can be supplied with oil ports oriented in different configuration in relation to the drive shaft, as follows (viewed from the shaft end); Ports orientation can be easily changed by rotating the pump body that carries inlet port.

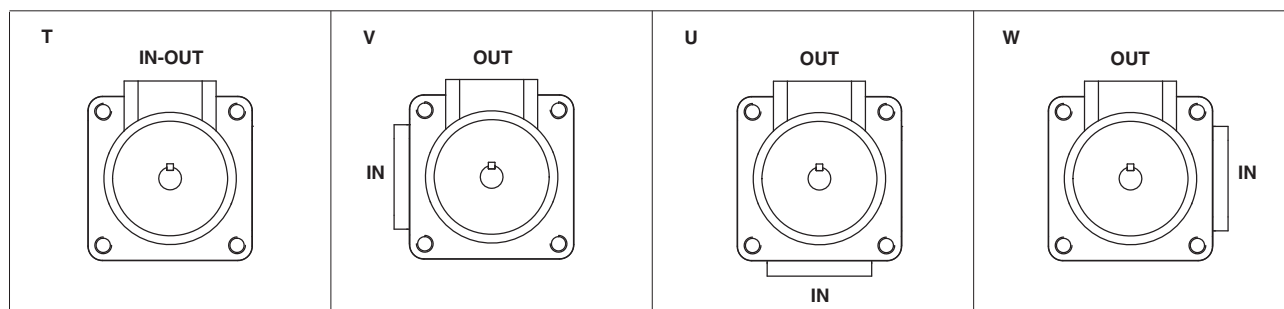

OUT = outlet port; IN = inlet port

**7 DIAGRAMS** (based on mineral oil ISO VG 46 at 50°C)

**Torque versus pressure diagram**

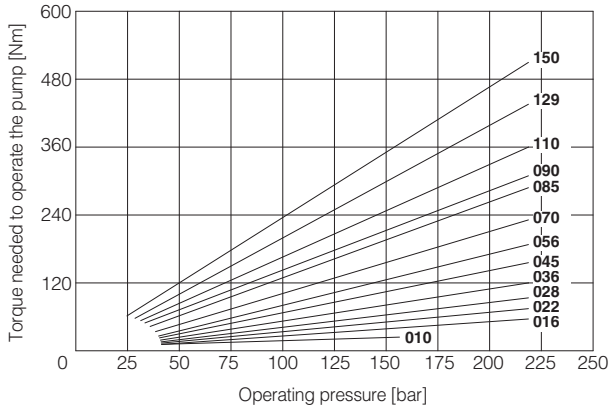

**Noise levels**

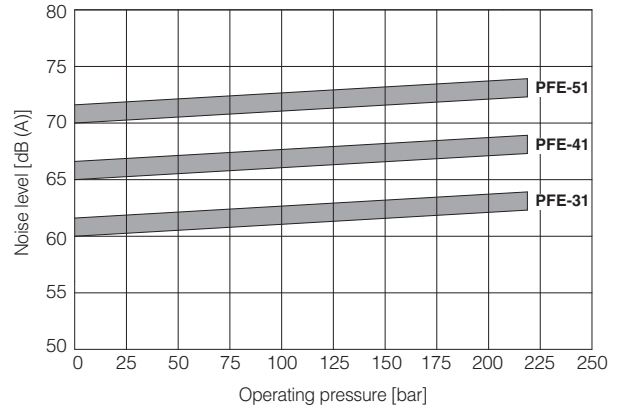

**PFE-31:**

**Flow versus speed diagram**

with pressure variation from 7 bar to 210 bar.

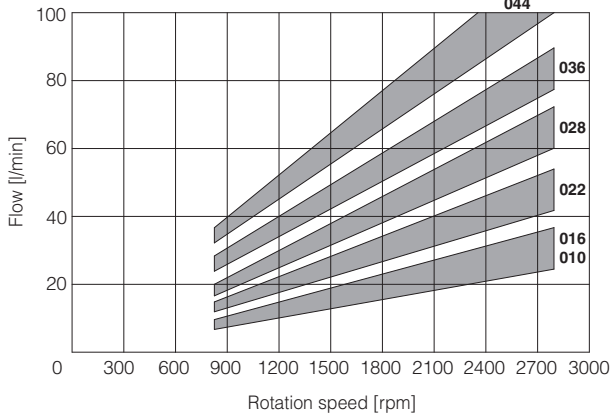

**Power consumption versus speed diagram** at 140 bar.

Power consumption is proportional to operating pressure.

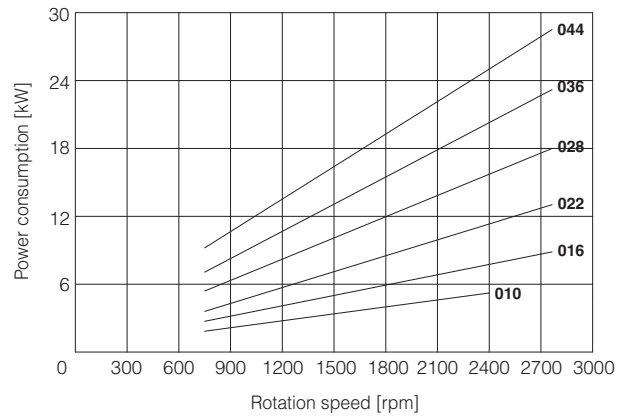

**PFE-41:**

**Flow versus speed diagram**

with pressure variation from 7 bar to 210 bar.

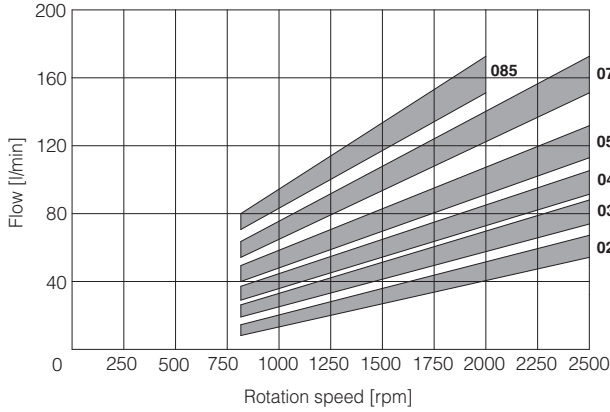

**Power consumption versus speed diagram** at 140 bar.

Power consumption is proportional to operating pressure.

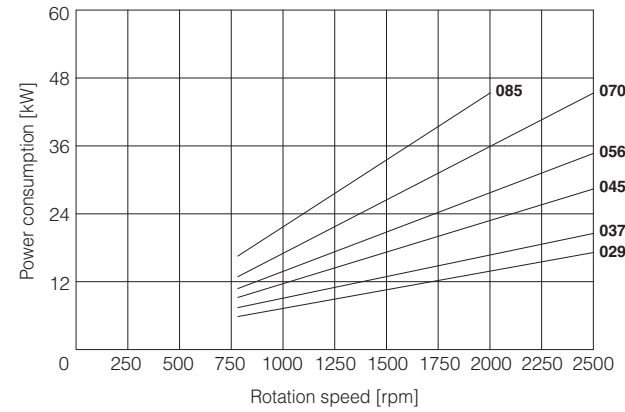

**PFE-51:**

**Flow versus speed diagram**

with pressure variation from 7 bar to 210 bar.

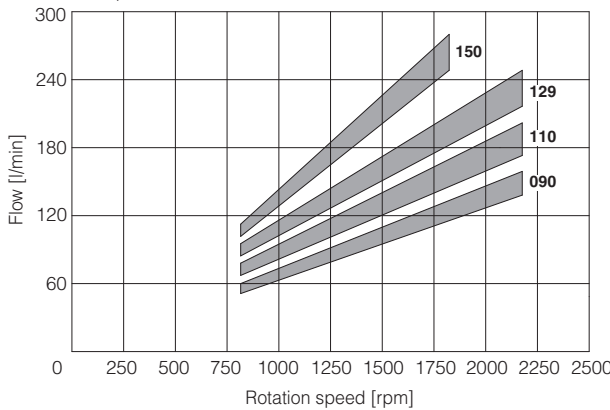

**Power consumption versus speed diagram** at 140 bar.

Power consumption is proportional to operating pressure.

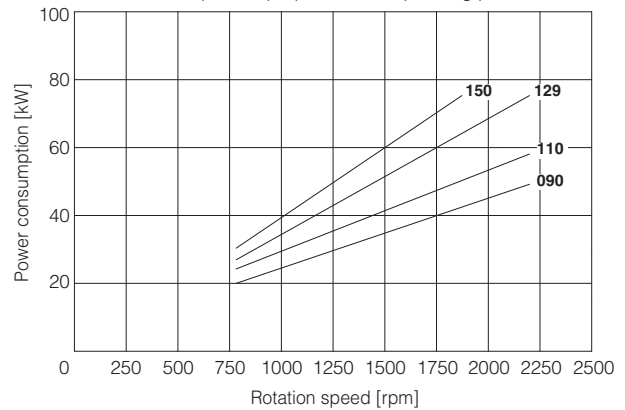

**8 DRIVE SHAFT**

**CYLINDRICAL SHAFT KEYED**

- 1 = for single and multiple pumps (only first position)
- 2 = for single and multiple pumps (only first position)  
long version (only for PFE-41 and PFE-51)
- 3 = for single and multiple pumps (only first position)  
for high torque applications

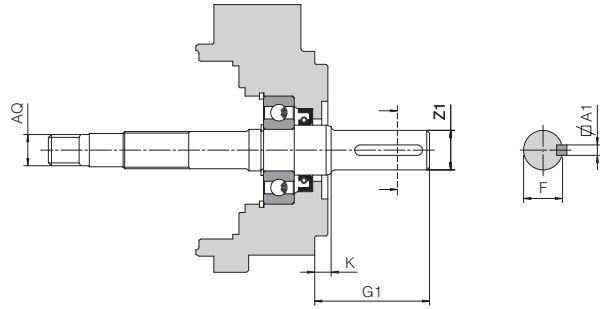

Pump size	Keyed shaft type 1 (standard)						Keyed shaft type 2						Keyed shaft type 3					
	A1	F	G1	K	ØZ1	Ø AQ <small>Only for through shaft execution</small>	A1	F	G1	K	ØZ1	Ø AQ <small>Only for through shaft execution</small>	A1	F	G1	K	ØZ1	Ø AQ <small>Only for through shaft execution</small>
PFE-31	4,78	21,11	56,00	8,00	19,05	SAE 16/32-9T	-	-	-	-	-	-	4,78	24,54	56,00	8,00	22,22	SAE 16/32-9T
	4,75	20,94			19,00								4,75	24,41			22,20	
PFE-41	4,78	24,54	59,00	11,40	22,22	SAE 32/64-24T	6,36	25,03	71,00	8,00	22,22	SAE 32/64-24T	6,38	28,30	78,00	11,40	25,38	SAE 32/64-24T
	4,75	24,41			22,20		6,35	24,77			22,20		6,35	28,10			25,36	
PFE-51	7,97	35,33	73,00	14	31,75	SAE 16/32-13T	7,95	35,33	84,00	8,10	31,75	SAE 16/32-13T	7,97	38,58	84,00	14	34,90	SAE 16/32-13T
	7,94	35,07			31,70		7,94	35,07			31,70		7,94	38,46			34,88	

**SPLINED SHAFT**

- 5 = for single and multiple pumps (any position)  
for PFE-31 according to SAE A 16/32 DP, 9 teeth;  
for PFE-41 according to SAE B 16/32 DP, 13 teeth;  
for PFE-51 according to SAE C 12/24 DP, 14 teeth;
- 6 = for single and multiple pumps (only first position)  
for PFE-31 and PFEX\*-31 according to SAE B 16/32 DP, 13 teeth;  
for PFE-41 and PFEX\*-41 according to SAE C 12/24 DP, 14 teeth;
- 7 = for second and third position pump in multiple configuration:  
for PFEX\*-31 according to SAE B 16/32 DP, 13 teeth;  
for PFEX\*-41 according to SAE C 12/24 DP, 14 teeth;

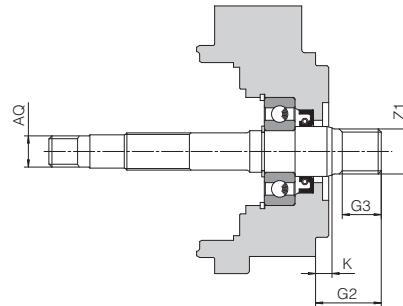

Pump size	Splined shaft type 5					Splined shaft type 6					Splined shaft type 7				
	G2	G3	K	Z1	Ø AQ <small>Only for through shaft execution</small>	G2	G3	K	Z1	Ø AQ <small>Only for through shaft execution</small>	G2	G3	K	Z1	Ø AQ <small>Only for through shaft execution</small>
PFE-31	32,00	19,50	6,50	SAE 16/32-9T	SAE 16/32-9T	41,00	28	8,00	SAE 16/32-13T	SAE 16/32-9T	32,00	19	8,00	SAE 16/32-13T	SAE 16/32-9T
PFE-41	41,25	28	8,00	SAE 16/32-13T	SAE 32/64-24T	55,60	42	8,00	SAE 12/24-14T	SAE 32/64-24T	41,60	28	8,00	SAE 12/24-14T	SAE 32/64-24T
PFE-51	56,00	42	8,10	SAE 12/24-14T	SAE 16/32-13T	-	-	-	-	-	-	-	-	-	-

**9 LIMITS OF SHAFT TORQUE**

Pump size	Maximum driving torque [Nm]						Maximum torque available at the end of the through shaft [Nm]
	Shaft type 1	Shaft type 2	Shaft type 3	Shaft type 5	Shaft type 6	Shaft type 7	
PFE-31	160	-	240	110	240	240	130
PFE-41	250	250	400	200	400	400	250
PFE-51	500	500	850	450	-	-	400

The values of torque required to operate the pumps are shown for each type on the "torque versus pressure" diagram at section 6. In multiple pumps the total torque applied to the shaft of the first element (drive shaft) is the sum of the single torque needed for operating each single pump and it is necessary to verify that this total torque applied to the drive shaft is not higher than the values indicated in the table.

10 DIMENSIONS OF SINGLE PUMPS [mm]

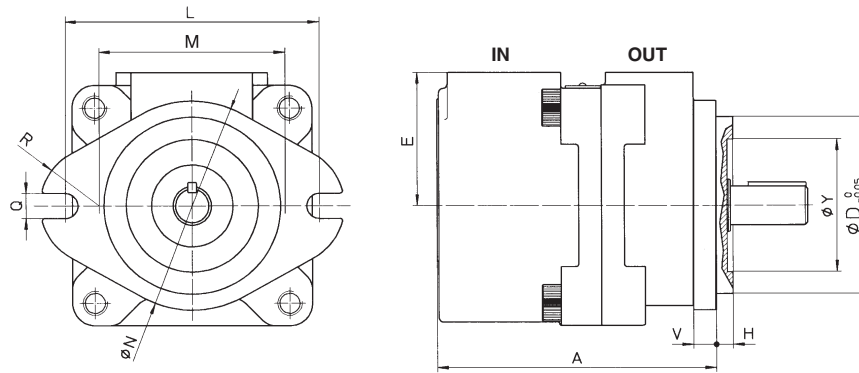

**PORTS DIMENSION (SAE 3000)**

**PFE-31:** IN = 1 1/4"; OUT = 3/4"  
**PFE-41:** IN = 1 1/2"; OUT = 1"  
**PFE-51:** IN = 2"; OUT = 1 1/4"

**Mass:**

PFE-31 = 9 kg  
 PFE-41 = 14 kg  
 PFE-51 = 25,5 kg

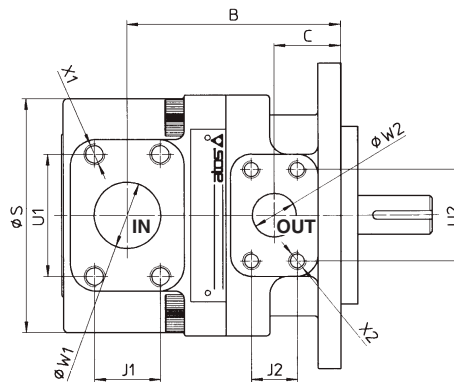

Pump size	A	B	C	ØD	E	H	L	M	ØN	Q	R
<b>PFE-31</b>	136	100	28	82,55	70	6,4	106	73	95	11,1	28,5
<b>PFE-41</b>	160	120	38	101,6	76,2	9,7	146	107	120	14,3	34
<b>PFE-51</b>	186,5	125	38	127	82,6	12,7	181	143,5	148	17,5	35
Pump size	ØS	U1	U2	V	ØW1	ØW2	J1	J2	X1	X2	ØY
<b>PFE-31</b>	114	58,7	47,6	10	32	19	30,2	22,2	M10X20	M10X17	47
<b>PFE-41</b>	134	70	52,4	13	38	25	35,7	26,2	M12X20	M10X17	76
<b>PFE-51</b>	160	77,8	58,7	15	51	32	42,9	30,2	M12X20	M10X20	76

**11 DIMENSIONS OF PUMPS WITH THROUGH-SHAFT (XA\*, XB\*, XC options) [mm]**

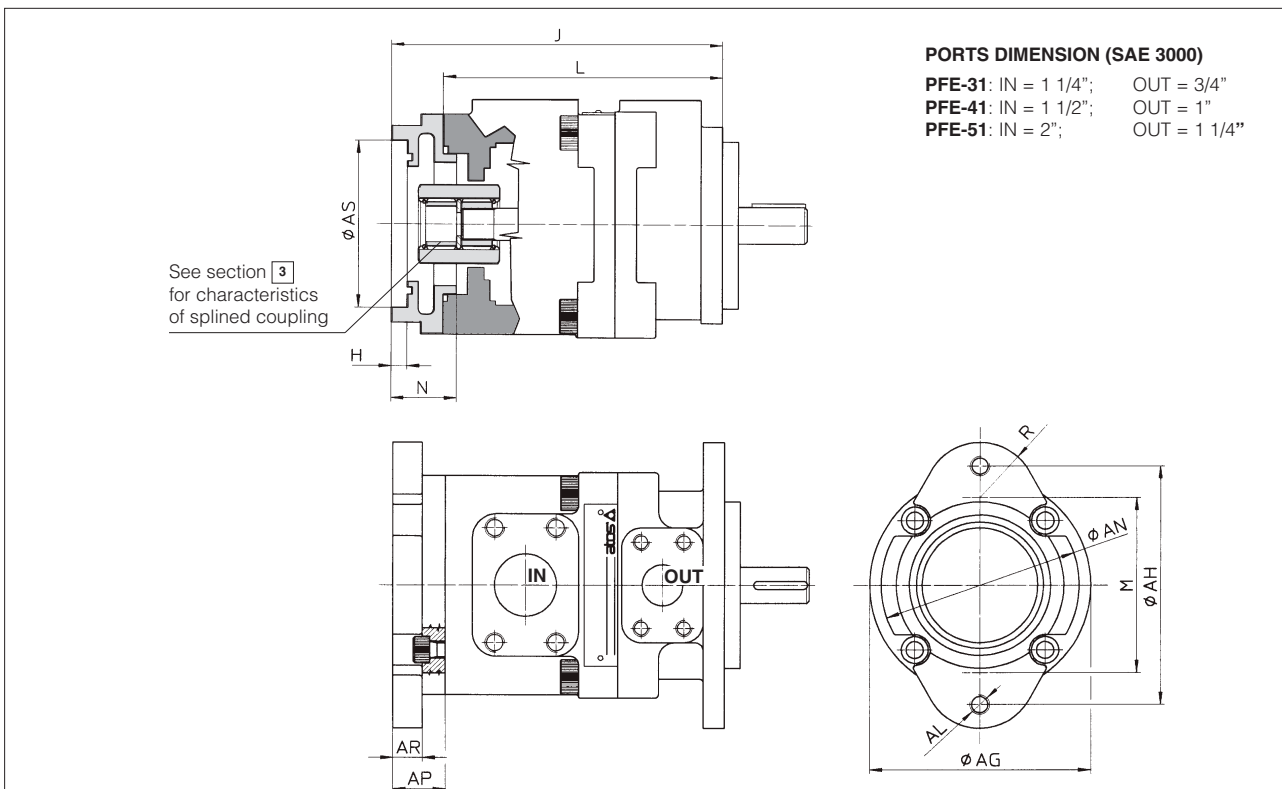

For other dimensions, see section 10

Pump size	Ø AG	Ø AH	AL	Tightening torque (Nm) (1)	Ø AN	AP	AR	Ø AS	H	J	L	M	N	R
PFE <del>X</del> A-31	114	106	M10X17	70	95	33	25	82,57 82,63	6,42 6,47	165,5	132,5	79	32	28,5
PFE <del>X</del> A-41	134	106	M10X17	70	95	23	11	82,57 82,63	6,42 6,47	194	171	73	32	28,5
PFE <del>X</del> B-41	134	146	M12	125	120	32	18	101,62 101,68	9,73 9,78	203	171	107	41	34
PFE <del>X</del> A-51	134	106	M10X17	70	95	22,7	11	82,57 82,63	6,42 6,47	206,2	183,5	73	32	28,5
PFE <del>X</del> B-51	134	146	M12	125	120	32	18	101,62 101,68	9,73 9,78	215,5	183,5	107	41	34
PFE <del>X</del> C-51	134	181	M16	300	148	46,5	30,7	127,02 127,02	12,73 12,78	230	183,5	143,5	56	35

(1) Tightening torque for screw class 12.9

**12 DIMENSIONS OF PUMPS WITH THROUGH SHAFT, WITHOUT REAR FLANGE (XO option) [mm]**

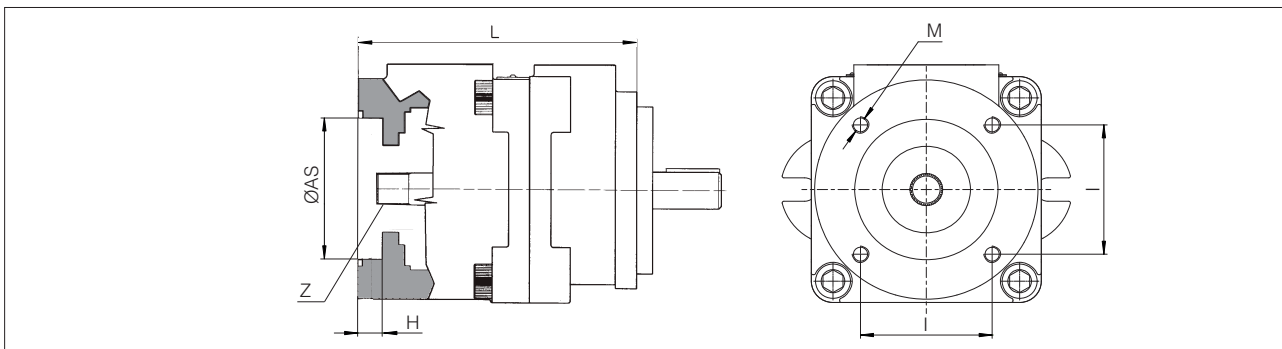

Pump size	L	Ø AS	H	M	I	Z
PFE <del>X</del> O-31	132.5	60 <sup>+0.03</sup> <sub>0</sub>	6.5	n°4 M6x13(max)	70	SAE 16/32-9T x15mm
PFE <del>X</del> O-41	171	86 <sup>+0.035</sup> <sub>0</sub>	15	n°4 M10x17(max)	79	SAE 32/64-24T x20mm
PFE <del>X</del> O-51	183.5	86 <sup>+0.035</sup> <sub>0</sub>	15	n°4 M10x17(max)	79	SAE 16/32-13T x20mm

**13 RELATED DOCUMENTATION**

<b>A900</b>	Operating and maintenance information for pumps
-------------	---