

Variable displacement vane pump (with mechanical pressure compensator)

## PVS-Type

### Key Features:

- Rotation:** Right (viewed from shaft end)  
**Mounting flanges:** 4-hole flange (UNI ISO 3019/2)  
**Connections:** GAS BSP (UNI ISO 228/1) and SAE  
**Mechanical displacement limiter "Q" on request**  
 All pumps are already set up as standard to be coupled to each other and with other types of pump

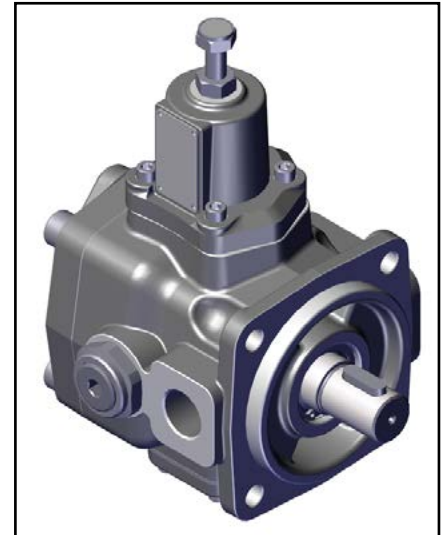

Series/Name	Rated Displacement (cm <sup>3</sup> /r)	Maximum Flow Capacity at 1450 rpm (L/min)	Maximum Pressure (bar)
02-PVS-2-40	40	58	100
02-PVS-2-50	50	73	100
02-PVS-3-63	63	91	80
02-PVS-3-80	80	116	80
02-PVS-3-100	100	145	80

**CONTENTS**

GENERAL DESCRIPTION ..... C-3

CHARACTERISTICS ..... C-4

ORDERING CODE ..... C-5

TECHNICAL DATA ..... C-6

COMBINED PUMPS..... C-7

CHARACTERISTIC CURVES..... C-10

OVERALL DIMENSIONS ..... C-12

ACCESSORIES ..... C-13

INSTRUCTIONS FOR INSTALLATION AND USE ..... C-15

**WARNING**

All Berarma pumps have been carefully checked during manufacture and subjected to stringent testing cycles before shipment. To achieve optimum performance, avoid problems and maintain the warranty, the installation instructions enclosed with each pump sold must be strictly observed.

**NOTES**

Before selection and/or use of any Berarma product, it is important that the purchaser carefully analyses all aspects of its application and reviews the information in the current Berarma Technical-Sales catalogues. Due to the many different operating conditions and applications for Berarma products, the purchaser, through their own analysis and testing, is solely responsible for making the final selection of the products and assuring that all performance and safety requirements are met.

Berarma S.r.l. accepts no responsibility for any editing mistakes in this catalogue.

Berarma S.r.l. reserves the right to modify the products and data contained in this catalogue at any time and without prior notice.

## GENERAL DESCRIPTION

Berarma PVS variable displacement vane pumps come in 2 nominal sizes: Size 2-3.

The PVS low pressure pumps (100 bar) are equipped with a MECHANICAL pressure regulating device.

Pump components include: a body (1), a drive rotor (2) which houses the vanes (3), vanes that transport the fluid into the inlet and outlet chambers; a stator (4) (mobile circular ring) for varying eccentricity and consequently displacement; side distribution plates with AXIAL HYDROSTATIC COMPENSATION (5) which delimit the inlet and outlet chambers; a guide block balancing adjustment screw (6) (absolutely must not be tampered with by the user); a displacement adjustment piston (7), a maximum volume adjustment screw (8) (available on request); a pressure control device (9); and a pressure regulator (10).

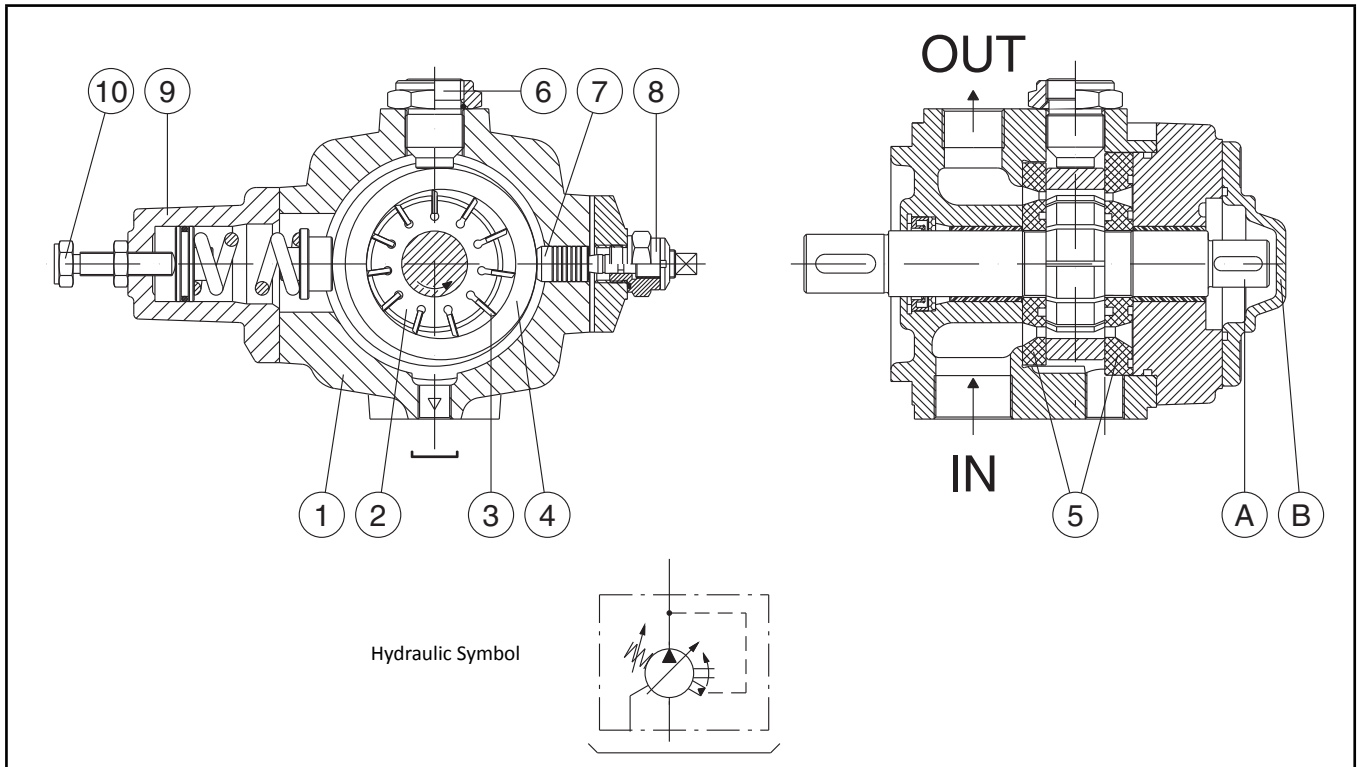

**CHARACTERISTICS**

- SILENT RUNNING from 60 to 72 dB(A)
- HIGH EFFICIENCY
- LONG WORKING LIFE thanks to quality materials and state-of-the-art manufacturing technology: hydrodynamic lubrication of bearings and hydrostatic balancing of distribution plates
- ECONOMY AND SIMPLIFICATION OF HYDRAULIC SYSTEM
- The pumps can be supplied with various proportional devices for flow, pressure and power control
- ISO standard MOUNTING FLANGES
- GAS (BSP), SAE standard PORT CONNECTIONS
- MODULAR DESIGN - All Berarma pumps feature modular design for maximum flexibility and adaptability. The pumps comprise a body, common to each size, on which the various types of compensator devices (mechanical and hydraulic for pressure and volume control) can be mounted. The pump can therefore be converted from PVS to PSP and vice versa without any special modification, using the same standard pump body.

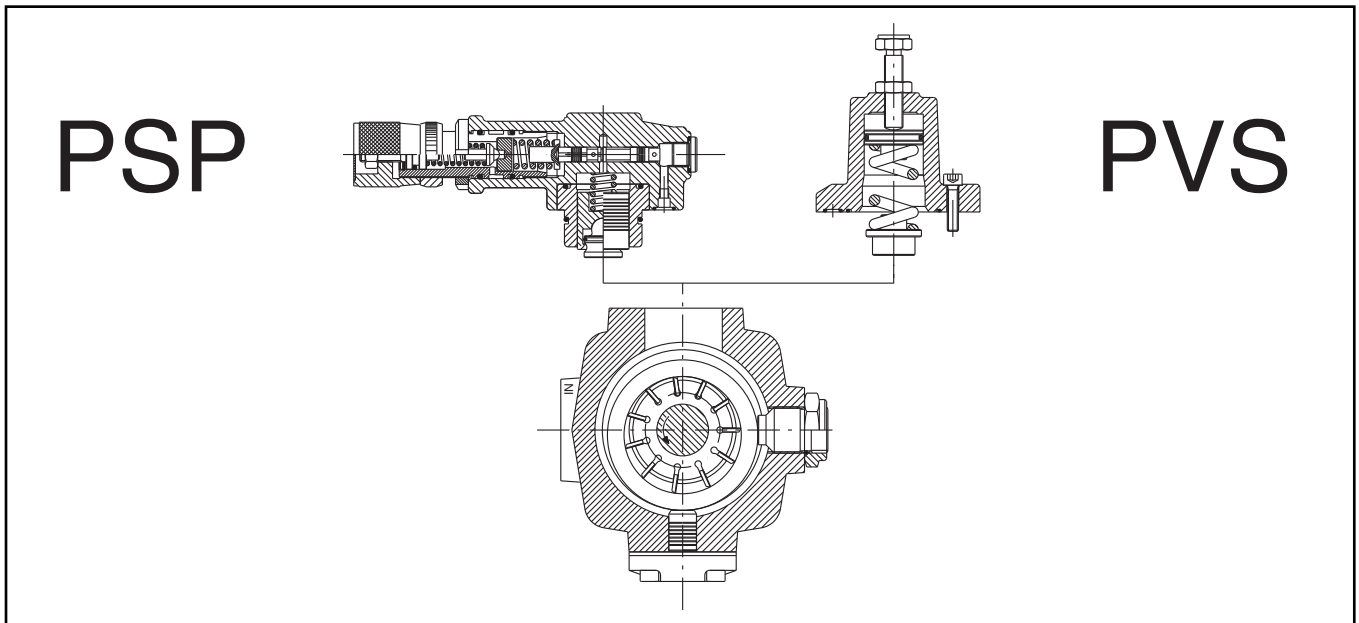

## ORDERING CODE

Series/ Name	Size Displacement	Flange	Pressure setting	Rotation	Seals	Options
<b>02 PVS</b>				<b>R</b>		

Code	Size	Displacement (cm <sup>3</sup> /r)
<b>2 - 40</b>	2	40
<b>2 - 50</b>	2	50
<b>3 - 63</b>	3	63
<b>3 - 80</b>	3	80
<b>3 - 100</b>	3	100

Code	Flange	Thread
<b>F</b>	UNI ISO3019/2 - 4 holes	GAS UNI ISO 228/1; SAE

Code	Pressure setting
<b>H</b>	30 - 100 bar (for Size 2) 30 - 80 bar (for Size 3)
<b>L</b>	15 - 50 bar

Code	Rotation Direction
<b>R</b>	Right (viewed from shaft end)

Code	Seals
<b>M</b>	NBR
<b>E</b>	FPM (viton)

Code	Options
<b>KL</b>	Key-Lock Compensator
<b>Q</b>	Displacement adjustment

Ordering code example:

- 02 PVS 2-40 F H R M
- 02 PVS 3-80 F H R M Q
- 02 PVS 3-100 F L R M

**ORDERING CODE**

**TECHNICAL DATA**

NOMINAL SIZE	SIZE 2	SIZE 3
Geometric displacement according to UNI-ISO 3662 (cm <sup>3</sup> /r)	40-50	63-80-100
Actual displacement (cm <sup>3</sup> /r)	42.8-53.1	69-86.2-105.5
Maximum working pressure (bar)	100	80
Pressure setting range	L - 15 / 50 bar H - 30 / 100 bar	L - 15 / 50 bar H - 30 / 80 bar
Permitted maximum drain port pressure (bar)	1	
Inlet pressure (absolute - bar)	0.8 - 1.5	
Speed range (r/min)	800 - 1800	
Rotation direction (viewed from shaft end)	Right (clockwise) R	
Loads on drive shaft	NO RADIAL OR AXIAL LOADS ALLOWED	
Maximum torque on primary shaft (Nm)	400	740
Hydraulic fluid	HM hydraulic oil according to ISO 6743/4; HLP hydraulic oil according to DIN 51524/2; organic ester HFD-U according to ISO 6743/4 (Quintolubric 888); for other fluids contact Berarma Technical-Sales Service	
Viscosity range (cSt, mm <sup>2</sup> /s)	22 - 68	
Starting viscosity under full flow conditions (cSt, mm <sup>2</sup> /s)	400 max	
Viscosity index according to ISO 2909	100 min	
Inlet fluid temperature range (°C)	-10 - +50	
Maximum acceptable fluid contamination level	20/18/15 according to ISO 4406/99, CLASS 9 according to NAS 1638	
Recommended fluid contamination level for a longer pump working life	18/16/13 according to ISO 4406/99, CLASS 7 according to NAS 1638	
Weight (kg)	32	44
For different operating conditions, please contact Berarma Technical Service		

## COMBINED PUMPS

BERARMA pumps are already set up for coupling to one another or to other types of pump (see table of possible combinations). The standard rotor shaft is set up for coupling (see pump section view, detail "A", on page 3). After removal of cover "B", the pump can be fitted with the different units already set up for coupling. With this solution BERARMA intends to avoid pumps with non-standard special applications, in order to simplify interchangeability and pump combination.

For solutions different to the ones described, please contact Berarma Technical Service.

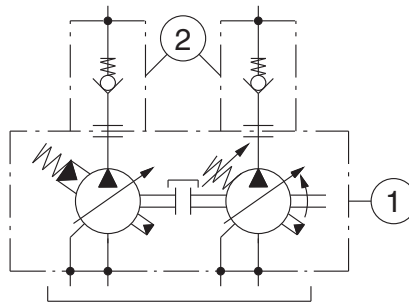

1) Combined Pumps

2) Non return valves - recommended installation (supplied on request)

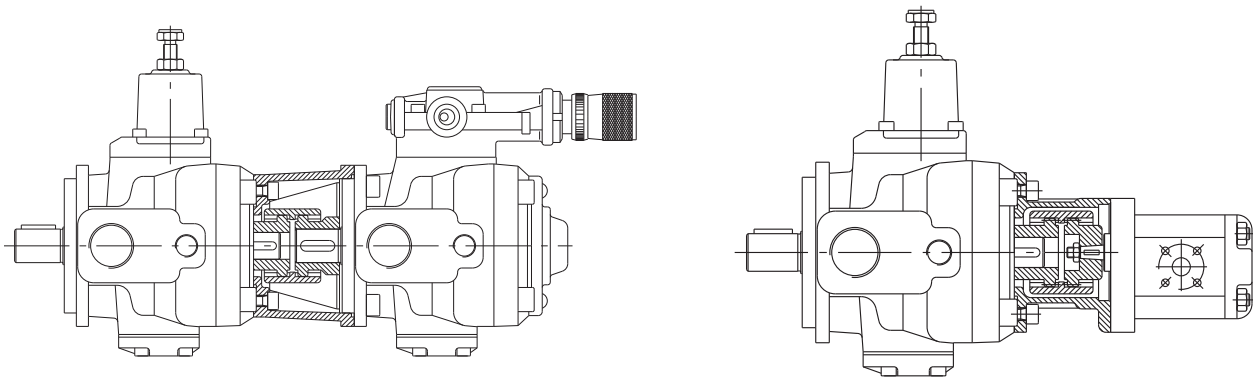

The ordering code should be specified according to the coupling sequence

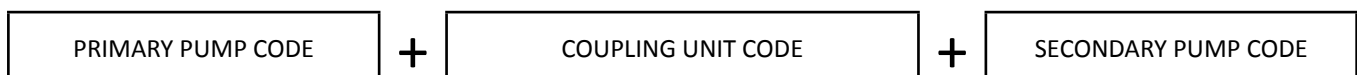

Combined pumps should be mounted in decreasing order of absorbed power, paying attention to the maximum acceptable torques (see diagram below).

The ordering code for a combined pump should be specified according to coupling sequence (primary pump code + coupling unit code + secondary pump code).

- The sum of individual torques of all pumps in the complete pump combination must not exceed the maximum permissible torque value applicable to the primary pump shaft ( $T_{max}$  see page 6).
- Secondary pump torque (or sum of torques for more than one secondary pump) must not exceed the coupling unit maximum thru drive torque ( $T_a$ , see table below).

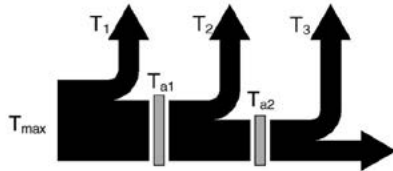

$$\begin{cases} T_1 + T_2 + T_3 < T_{max} \\ T_2 + T_3 < T_{a1} \\ T_3 < T_{a2} \end{cases}$$

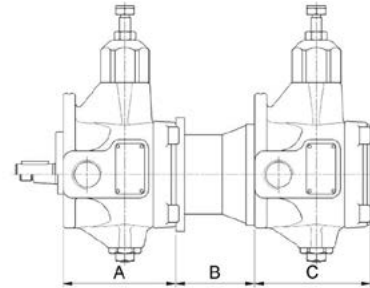

PRIMARY PUMP		SECONDARY PUMP		COUPLING UNIT		
Pump type	A	Pump type	C	Code	B	Maximum thru drive torque $T_a$
02 PVS 2 (40-50) F	173	GEAR PUMP SIZE 1P	(*)	3000022000	90	110 Nm
		GEAR PUMP SIZE 1	(*)	3000022100	90	
		GEAR PUMP SIZE 2	(*)	3000022200	90	
		GEAR PUMP SIZE 3	(*)	3000022300	90	
		01 PLP 05 16 F	107	3000020400	85	
		01 PLP 05 16 FGR2	107	3000022200	90	
		01 PHP 05 16 F	145	3000020400	85	
		01 PHP 05 16 FGR2	145	3000022200	90	
		01 PLP 1 (20-25-32) F	166	3000020100	87	
		01 PHP 1 (20-25-32)F	166	3000020100	87	
		02 PVS 2 (40-50) F	220	3000020200	102	
		02 PSP 2 (40-50) F	220	3000020200	102	
		SAE "A"	(*)	3100000200	100.5	
		SAE "B"	(*)	3100000300	126.5	
02 PVS 3 (63-80-100) F	198	GEAR PUMP SIZE 1P	(*)	3000022000	90	110 Nm
		GEAR PUMP SIZE 1	(*)	3000022100	90	
		GEAR PUMP SIZE 2	(*)	3000022200	90	
		GEAR PUMP SIZE 3	(*)	3000022300	90	
		01 PLP 05 16 F	107	3000020400	85	
		01 PLP 05 16 FGR2	107	3000022200	90	
		01 PHP 05 16 F	145	3000020400	85	
		01 PHP 05 16 FGR2	145	3000022200	90	
		01 PLP 1 (20-25-32) F	166	3000020100	87	
		01 PHP 1 (20-25-32)F	166	3000020100	87	
		02 PVS 2 (40-50) F	220	3000020200	102	
		02 PSP 2 (40-50) F	220	3000020200	102	
		SAE "A"	(*)	3100000200	100.5	
		SAE "B"	(*)	3100000300	126.5	
02 PVS 3 (63-80-100) F	245	3000020300	117	180 Nm		
02 PSP 3 (63-80-100) F	245	3000020300	117			

(\*) For the secondary pump SAE A flange dimensions please see page 9.  
In order to find out the secondary SAE flange pump axial dimension please see the manufacturer's catalogue.

(\*\*) For the secondary gear pump flange dimensions please see page 9.  
In order find out the secondary gear pump axial dimension please see the manufacturer's catalogue.

For other coupling unit types, please contact Berarma Technical-Sales Service.



SAE FLANGE DIMENSIONS FOR BERARMA COUPLING KIT

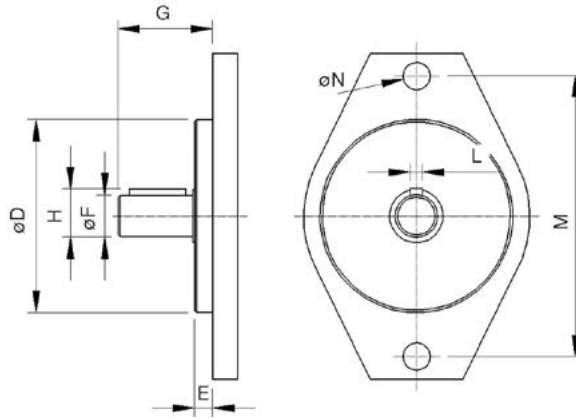

Secondary pump	Secondary pump with SAE flange should conform to the dimensions below								
	$\varnothing D$	E	$\varnothing F$	G		H	L	M	$\varnothing N$
				min	max				
SAE "A"	$\varnothing 82.5$	7	$\varnothing 19.05$	32	59	21.1	4.8	106.4	11.1
SAE "B"	$\varnothing 101.6$	9.5	$\varnothing 22.2$	41	71	25.1	6.375	146	14.3
						25.5	4.8		

GEAR PUMP FLANGE DIMENSIONS FOR BERARMA COUPLING KIT

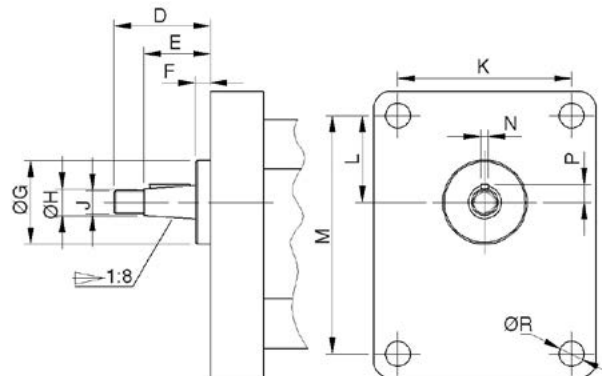

Secondary pump	Secondary gear pumps should conform to the dimensions below											
	D	E	F	$\varnothing G$	$\varnothing H$	J	K	L	M	N	P	$\varnothing R$
gear pump 1P	29	20	4	25.4	8	M7	52.4	26.2	71.9	2.4	5.3	7.5
gear pump 1	35	23.5	5.5	30	12	M10x1	56	24.5	73	3	7.9	6.5
gear pump 2	40	28	5	36.5	14.7	M12x1.5	71.5	32.5	96	4 (*)	9.7	8.5
gear pump 3	47	33	5	50.8	19	M14x1.5	98.5	43	128	4	12.2	11

**CHARACTERISTIC CURVES**

Indicative values related to 1450 r/min., HM hydraulic oil according to ISO 6743/4, ISO VG 32 according to ISO 3448, temperature 50°C

**02 PVS 2 40-50**

**volumetric efficiency -zero flow setting curve**

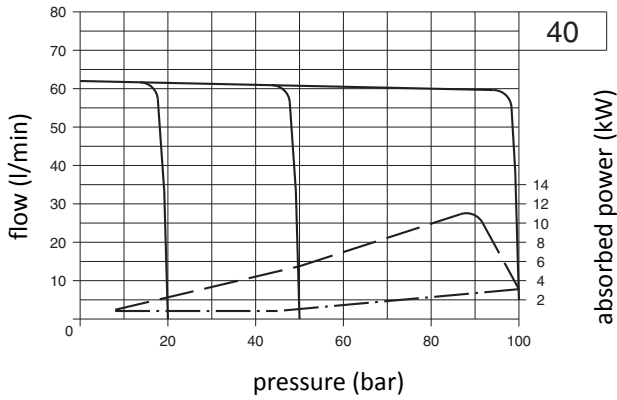

**data with pump under zero flow setting**

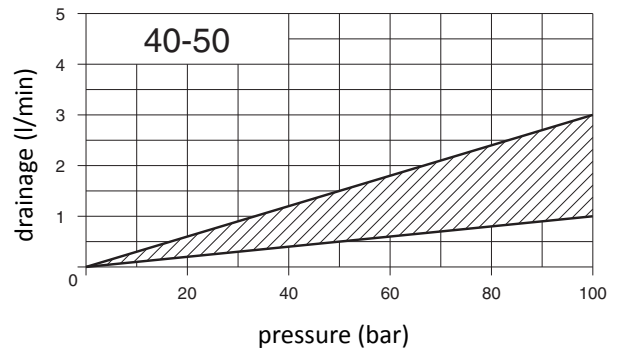

**volumetric efficiency -zero flow setting curve**

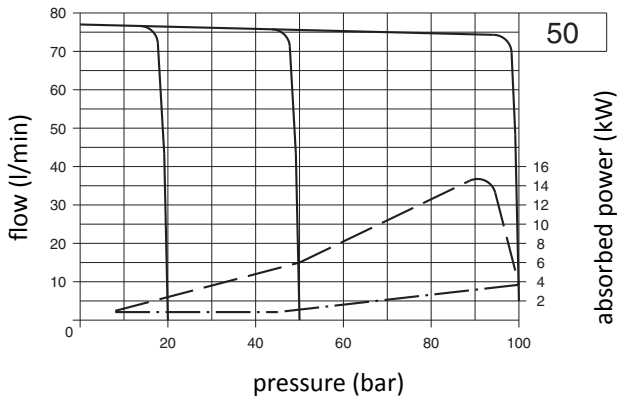

**Noise level**

Maximum noise level measured on Berarma test bench with sound-level meter placed 1 metre from the pump, with flexible coupling

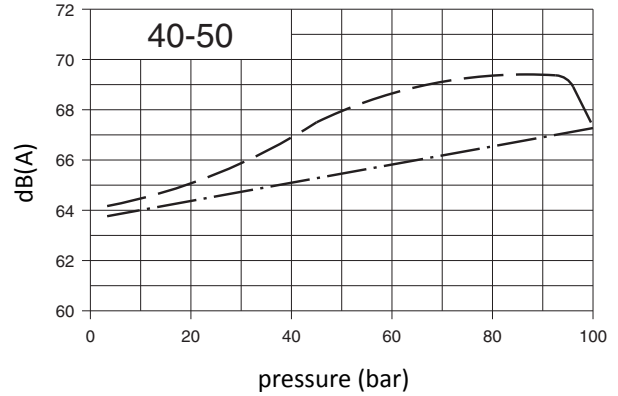

Power consumption with maximum flow

Power consumption with zero flow setting

**Response time and pressure peak**

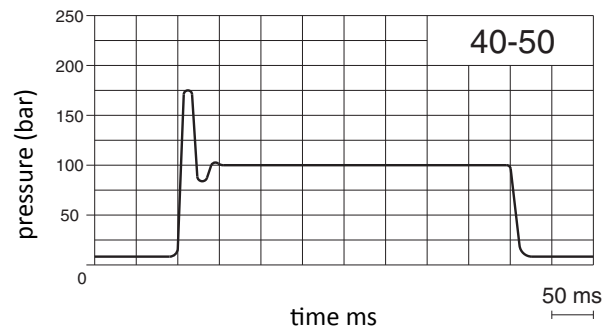

Pressure peaks are due to the test system. Pressure peaks exceeding 30% of the maximum operating pressure must be eliminated by adopting the appropriate measures.

Indicative values related to 1450 r/min., HM hydraulic oil according to ISO 6743/4, ISO VG 32 according to ISO 3448, temperature 50°C

**02 PVS 3 63-80-100**

**volumetric efficiency - zero flow setting curve**

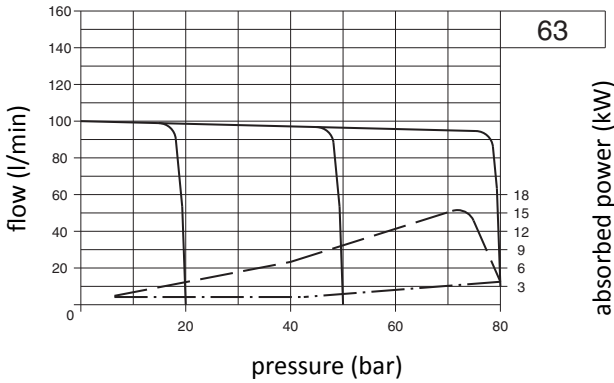

**data with pump under zero flow setting**

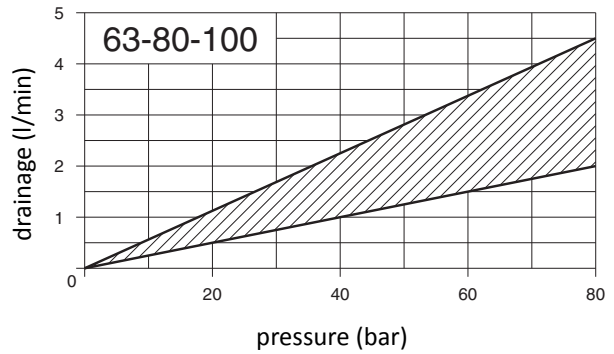

**volumetric efficiency - zero flow setting curve**

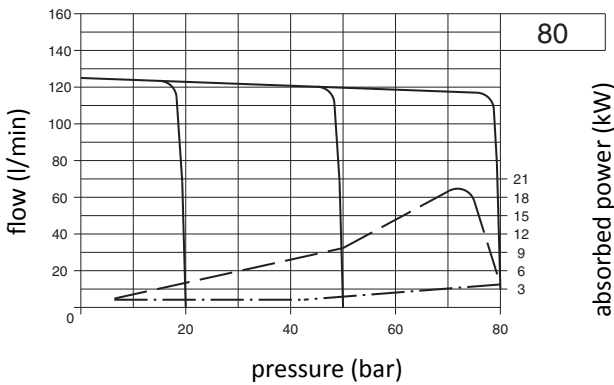

**Noise level**

Maximum noise level measured on Berarma test bench with sound-level meter placed 1 metre from the pump, with flexible coupling

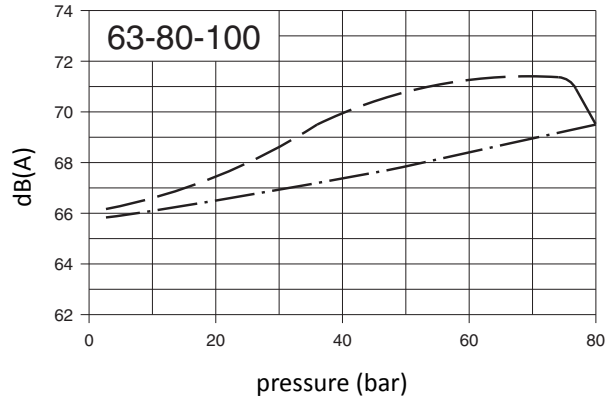

**volumetric efficiency - zero flow setting curve**

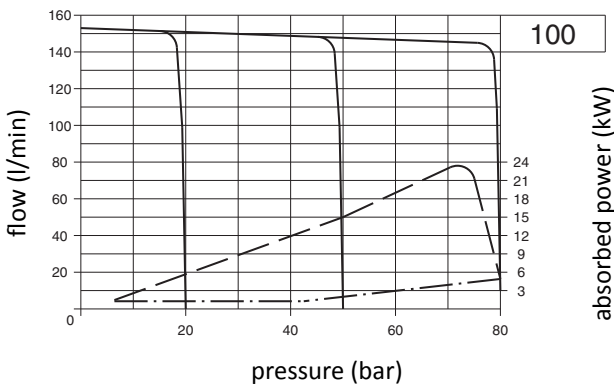

**Response time and pressure peak**

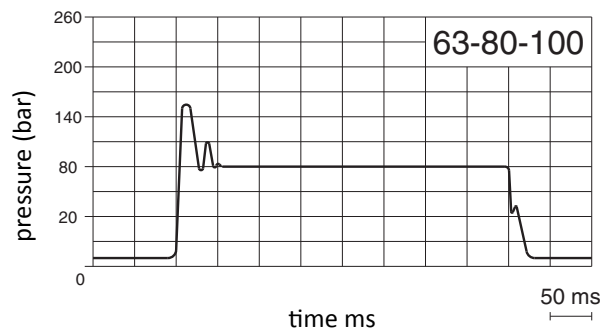

Power consumption with maximum flow

Power consumption with zero flow setting

Pressure peaks are due to the test system. Pressure peaks exceeding 30% of the maximum operating pressure must be eliminated by adopting the appropriate measures.

**OVERALL DIMENSIONS**

**02 PVS 2 40-50 (F)**

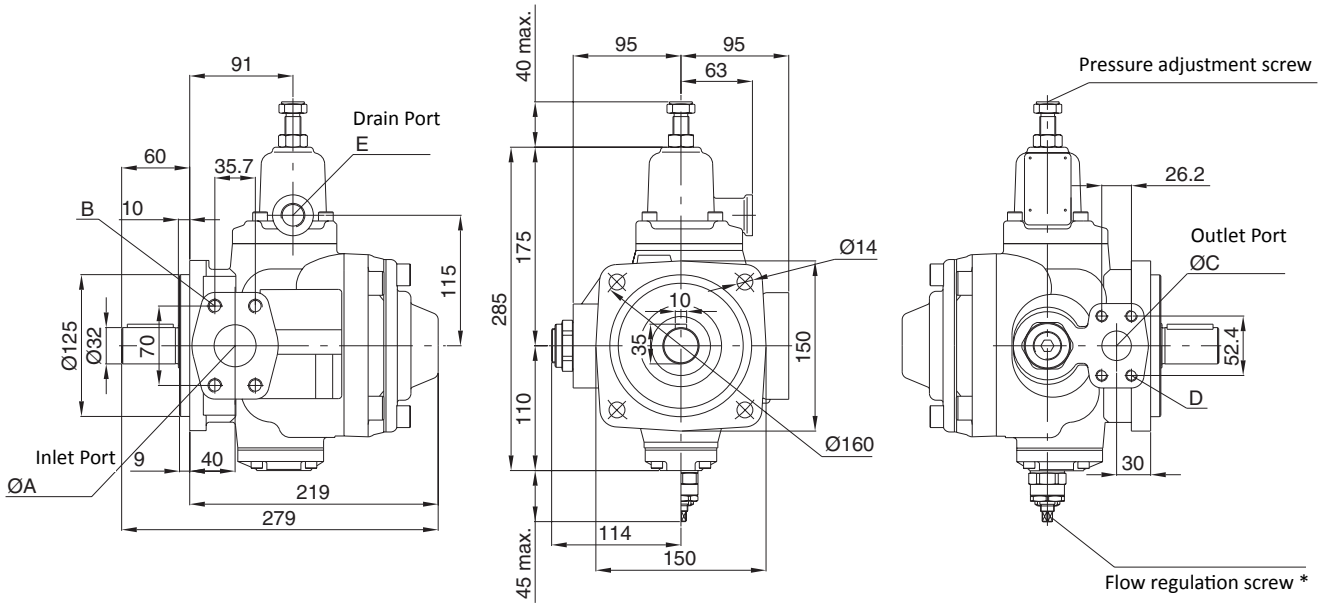

\*- Supplied on request (see page 14)

Flange	ØA	B	ØC	D	E
F (ISO)	38	SAE (3000) 1 1/2 M12 x 45	25	SAE (3000) 1" M10 x 35	1/2" Gas (BSP)

**02 PVS 3 63-80-100 (F)**

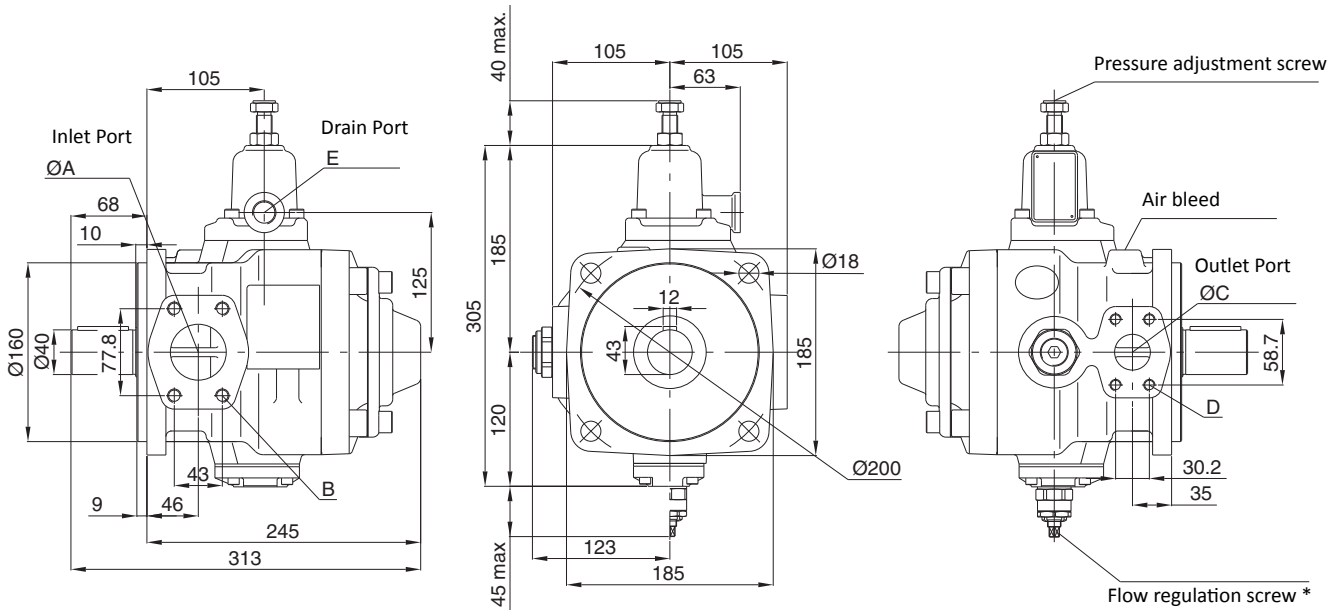

\*- Supplied on request (see page 14)

Flange	ØA	B	ØC	D	E
F (ISO)	51	SAE (3000) 2" M12 x 45	32	SAE (3000) 1 1/4" M10 x 40	1/2" Gas (BSP)

**ACCESSORIES**

**KEY-LOCK PRESSURE COMPENSATOR DEVICE**

02 PVS 2 ....-KL

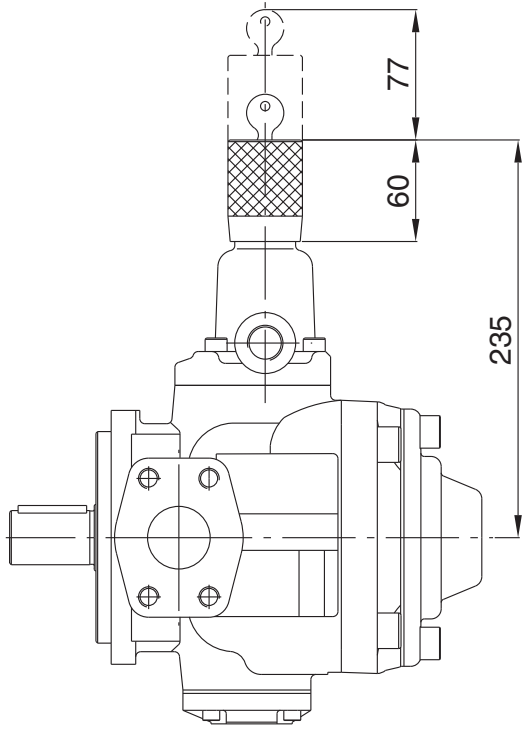

02 PVS 3 ....-KL

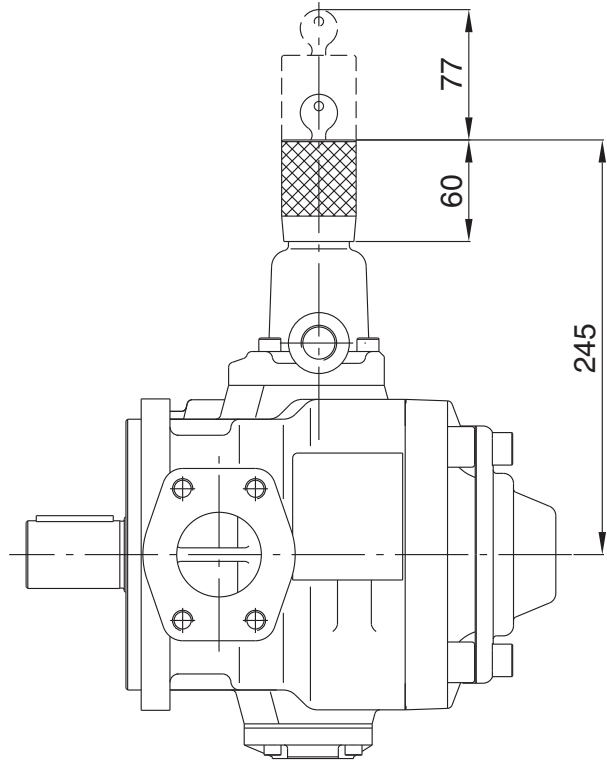

**FLOW-RATE REGULATOR UNIT**

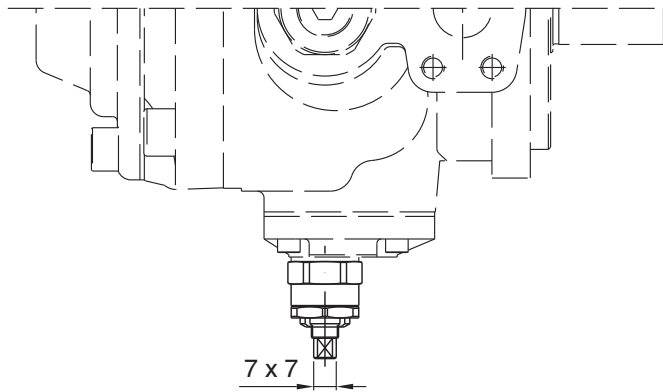

If the pump is supplied with flow-rate regulator unit "Q", set to less than 50% of the nominal flow, the pump can only start on condition that the system and pump are completely filled with fluid.

Pump type	02 PVS 2-40	02 PVS 2-50	02 PVS 3-63	02 PVS 3-80	02 PVS 3-100
Indicative data that can change from pump to pump					
MAX flow at 1450 r/min (l/min)	62	78	100	125	152
MIN flow at 1450 r/min (l/min)	14.3	30.3	14	39	66
Reduced flow by screw turn (l/min)	23.8	23.8	34.5	34.5	34.5

**FLANGES SAE J518 (3000 SERIES) SUPPLIED WITH SCREWS AND O-RING**

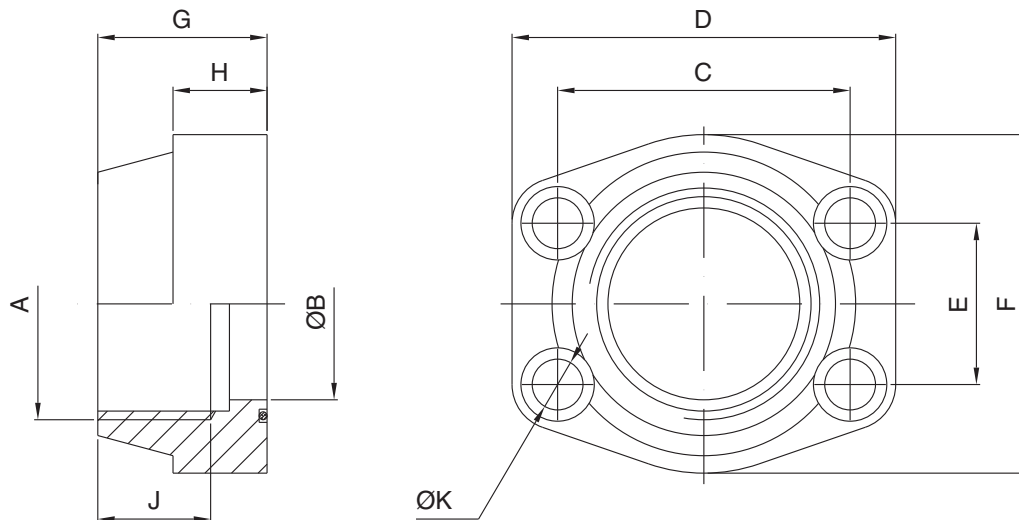

Pump type	Ordering code	Nominal size	A	ØB	C	D	E	F	G	H	J	ØK	Screws	O-Ring
02 PVS PSP 2	5540000102	1"	1" Gas (BSP)	25	52.4	70	26.2	52	38	18	19	11	M10	OR 4131 NBR
	5540000106	1" 1/2	1"½ Gas (BSP)	38	70	93	35.7	78	44	25	24	13.5	M12	OR 4187 NBR
02 PVS PSP 3	5540000104	1" 1/4	1"¼ Gas (BSP)	32	58.7	79	30.2	68	41	21	22	11.5	M10	OR 4150 NBR
	5540000108	2"	2" Gas (BSP)	51	77.8	102	42.9	90	45	25	30	13.5	M12	OR 4225 NBR



## INSTRUCTIONS FOR INSTALLATION AND USE

- Sizes 2 and 3 PVS pumps must be mounted with the shaft along a horizontal axis and with the compensator device facing upward (see figure).  
When the pump is installed above the tank oil level, pay attention to the inlet pressure (see page 6).  
The minimum section of the inlet pipe must be equal to the section of the thread of the pump inlet port. The inlet pipes should be as short as possible, with a small number of bends and without internal section changes.
- All return and drain pipes must be positioned so that the oil cannot be sucked back directly by the pump (see figure).  
The oil tank must be suitably sized in order to exchange the thermal power generated by the various system components and to provide a low recycle rate.  
To ensure the maximum pump working life, the inlet oil temperature must never be above 50°C. In systems where the pump runs for a long time under zero flow setting conditions, the installation of a heat exchanger in the drain line is recommended.  
The pressure on the drain port must never exceed the specified value (page 6).  
The drain pipe must always be independent from the other return lines, connected directly to the tank, and extended sufficiently inside the tank so as to be below the minimum oil level to avoid generating foam. Moreover, the drain pipe must be free of restrictions and as far as possible from the inlet pipe.
- Motor-pump coupling must be made with a self-aligning flexible coupling with convex teeth and a polyamide cam. When assembling, maximum attention must be given to the distance between the half-couplings which must strictly fall within the values specified in the diagram below (detail "A").  
Other types of motor-pump couplings are not permitted.  
No induced RADIAL or AXIAL LOADS are allowed on the pump shaft.
- During initial installation, the pump must be run under maximum flow conditions (P connected to T), with the oil flowing directly into the tank, in order to induce air bleeding. This phase must run for several minutes.  
Pump priming (delivery of oil to the outlet) must occur within a few seconds, otherwise the pump must be turned off and the operation repeated. Subsequent start-ups under zero flow setting conditions are admissible only with pressure not exceeding 30 bar, and with the system and pump completely filled with oil.  
During the initial and subsequent starting operations, the difference between the oil temperature and the ambient temperature (body pump temperature) must not exceed 20°C.

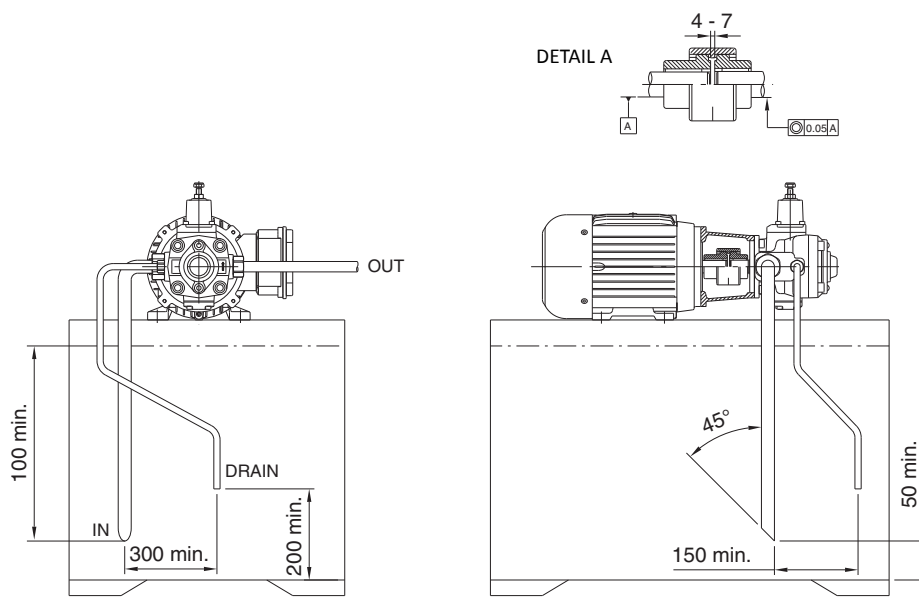

For further information, please consult the leaflet "Installation and start-up instructions for variable displacement vane combined pumps".

