

Dimensions

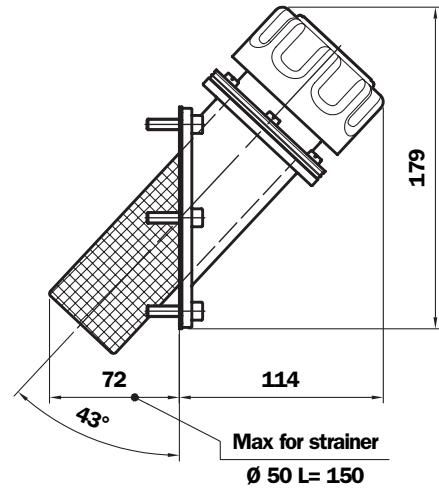

Flow rate with Δp : 0,02 bar

Filtration	l/min
3 μm	450
10 μm	550

Weight

TAL 80 1: 0,710 Kg

For tank hole see "SML 1" page 22.

Ordering information

Filler cap TAL80

Example: TAL80 **B 03 A 1 L 1 M P01**

1 - Filler cap connection

B Flange with bayonet connection

2 - Filter element

00 Without filter (Blank filler cap)

03 3 μm - Impregnated paper

10 10 μm - Polyurethane

3 - Seal

A NBR

B Cork gasket

4 - Pressurisation valve

0 Without

1 0,3 bar pressurisation valve

2 0,7 bar pressurisation valve

9 Anti-splash feature (only with filter element 3 μm)

Only with seal NBR

5 - Variants

0 Standard

L With Padlock tab

6 - Basket

0 Without

1 L= 80 mm

7 - Connection to reservoir

M Fixing with Metric screws

U Fixing with UNC screws

8 - Options

P01 MP Filtri standard