

PB型60/6X系列溢流阀

PB 60/6X SERIES PILOT OPERATED PRESSURE RELIEF VALVES

符号 SYMBOL

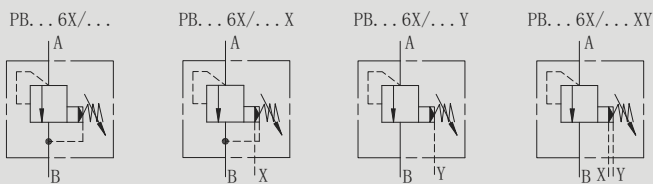

PB 型阀是先导控制式的溢流阀。用于控制液压系统的压力，并能在任意时刻使系统卸荷。

6X 系列 PB 型阀，性能优于 60 系列 PB，具有更平稳的调压性能，更低的最低调节压力和调压范围大通流能力更强等特点。

PB is pilot operated pressure relief valve.

The performance of 6X series is superior than 60 series, the 6X series can be used to control the pressure of hydraulic systems smoothly in a wide range. This type is suitable for a hydraulic system which demands high flow rate.

▶ 技术参数 Technical data

通径 Size		10		20		30	
系列号 Series No		60	6X	60	6X	60	6X
工作压力 (Mpa) Operating pressure (Mpa)		31.5	35	31.5	35	31.5	35
最大流量 (L/min) Max. flow rate (L/min)		200	250	400	500	600	650
介质温度 (°C) Fluid temperature (°C)		-20 ~ 70					
过滤精度 (μm) Filtration accuracy (μm)		25					
重量 (千克) Weight (KGS)	PB	3.2		4.2		5.2	
阀体 (材料) 表面处理 Valve body (Material) Surface treatment		铸件 表面磷化处理 casting phosphating surface					
油液清洁度 / Oil cleanliness		NAS1638 9 级和 ISO4406 20/18/15 级 NAS1638 class 9 and ISO4406 class 20/18/15					

特性曲线 (在使用 HLP46 , $t_{油}=40\text{ }^{\circ}\text{C} \pm 5\text{ }^{\circ}\text{C}$ 时测得)

Characteristic curves (measured with HLP46 , $Voil=40\text{ }^{\circ}\text{C} \pm 5\text{ }^{\circ}\text{C}$)

最低设定压力和旁通压力与流量的关系 Characteristic of Min.Setting Pressure.bypass pressure and flow
标准型 Standard

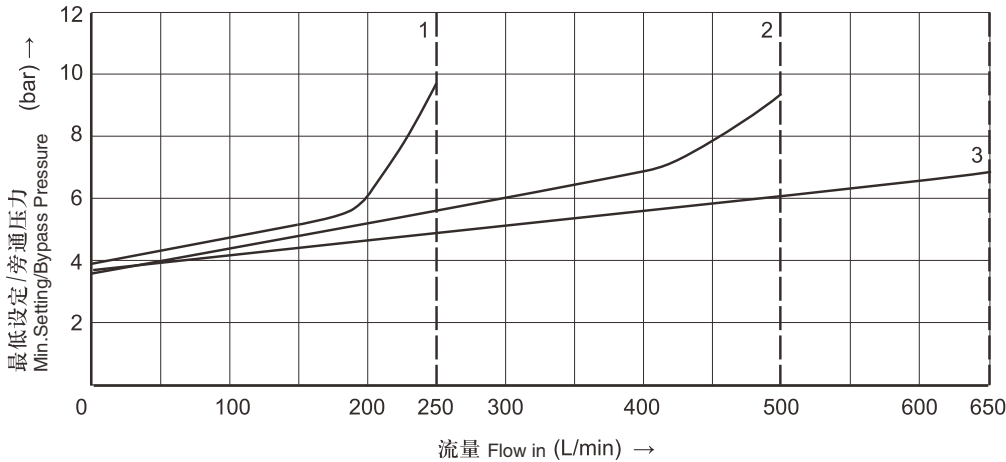

1. 通径 10 Size 10
2. 通径 20 Size 20
3. 通径 30 Size 30

最低设定压力和旁通压力与流量的关系 Charateristics of Min.Setting Pressure.bypass presure and flow
“U”型 Type "U"

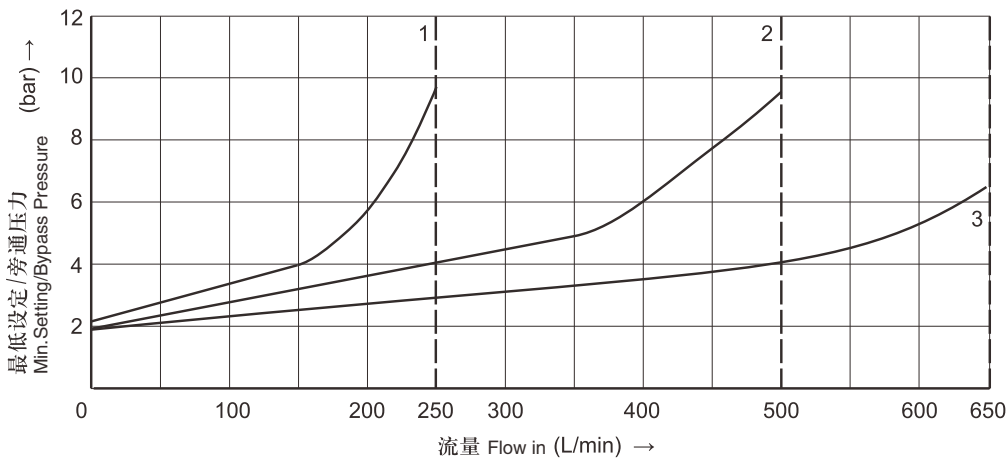

1. 通径 10 Size 10
2. 通径 20 Size 20
3. 通径 30 Size 30

注意!

此特性曲线在控制油外部零压回油时测得。
对于控制油内部回油, 进口压力增加了T口的压力值。

Attention !

The curves is measured without pressure when control oil back to the tank.
Refers to the back into housing of the control oil,the pressure of " T " port has increased against the input pressure.

此特性曲线在整个流量范围内对于出口压力 $p_t = 0$ 有效!

The curves are available when the output pressure $P_t=0$ within the flow ranges.

特性曲线 (在使用 HLP46 , 油=40 °C ± 5 °C时测得)
 Characteristic curves (measured with HLP46 , Voil=40 °C ± 5 °C)

进口压力与流量的关系 Characteristic of inlet Pressure and flow

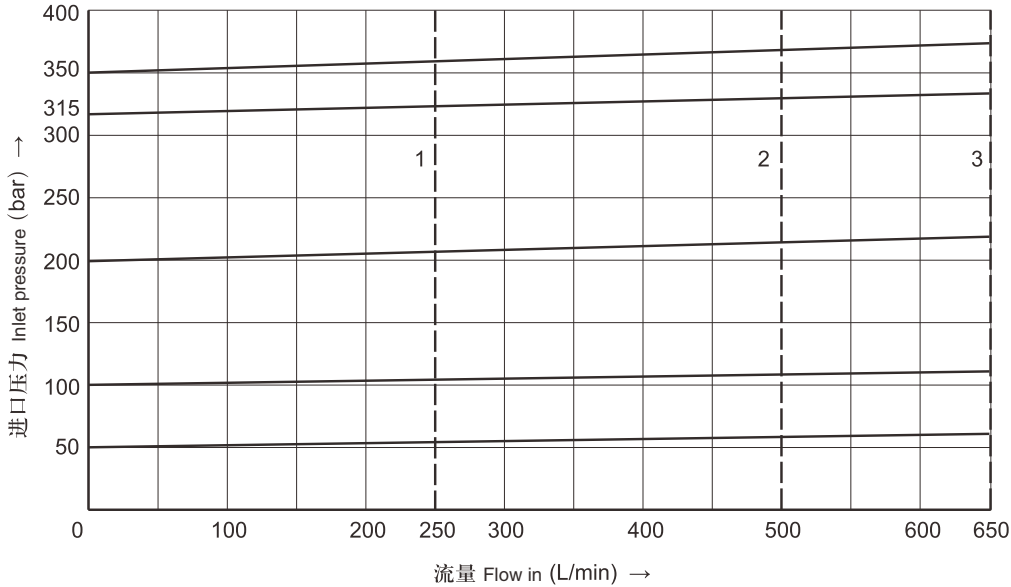

- 1. 通径 10 Size 10
- 2. 通径 20 Size 20
- 3. 通径 30 Size 30

注意!

此特性曲线在控制油外部零压回油时测得。
 对于控制油内部回油, 进口压力增加了T口的压力值。

Attention !

The curves is measured without pressure when control oil back to the tank.
 Refers to the back into housing of the control oil,the pressure of " T " port has increased against the input pressure.

特性曲线 (在使用 HLP46 , 油=40 °C ± 5 °C时测得)
 Characteristic curves (measured with HLP46 , Voil=40 °C ± 5 °C)

先导流量 Pilot flow

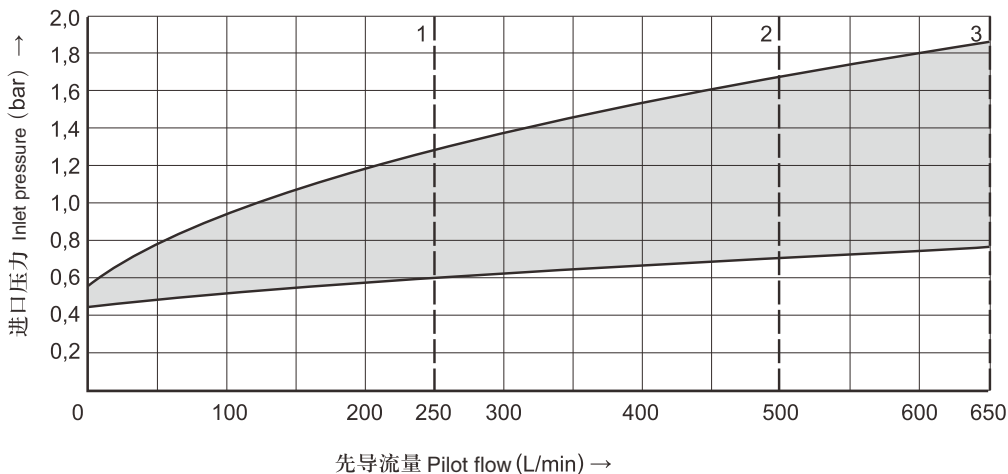

- 1. 通径 10 Size 10
- 2. 通径 20 Size 20
- 3. 通径 30 Size 30

▶ 板式底板安装尺寸 Subplate mounting

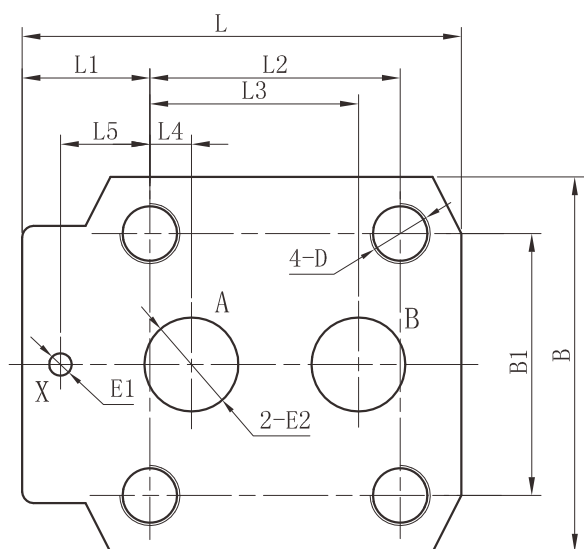

▶ 管式连接尺寸 Threaded connections

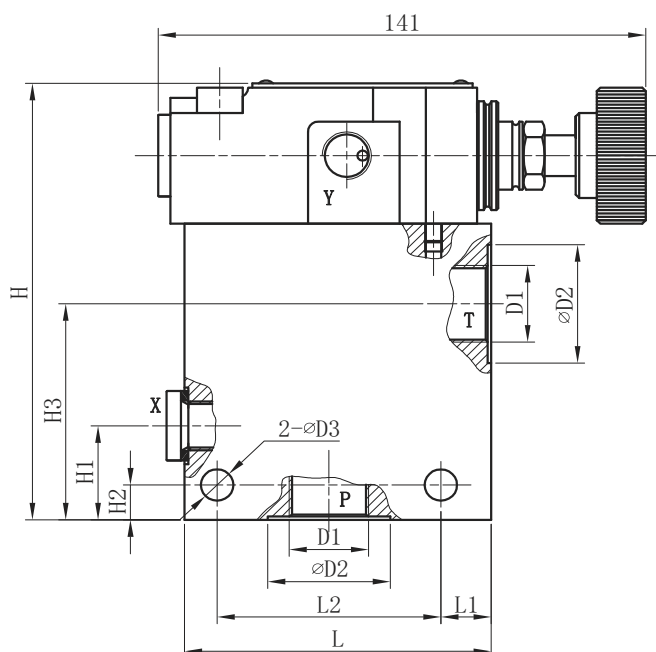

▶ 板式底板安装尺寸 Subplate mounting

型号 Model	L	L1	L2	L3	L4	L5	B	B1	D	E1	E2
PB10	90	23.5	54	47.6	22.2	0	78	54	M12/26	Φ 6	Φ 12
PB20	117	34	66.7	55.6	11.1	23.8	100	69.8	M16/26	Φ 6	Φ 25
PB30	148	41.5	88.7	76.2	12.7	31.7	115	82.5	M18/26	Φ 7	Φ 32

▶ 管式连接尺寸 Threaded connections

型号 Model	D1		D2	D3	L	L1	L2	H	H1	H2	H3
	公制 Metric	英制 Inch									
PB8G	M18 × 1.5	G 3/8"	28	9	85	14	62	125	27	10	62
PB10G	M22 × 1.5	G 1/2"	34	9	85	14	62	125	27	10	62
PB15G	M27 × 2	G 3/4"	42	9	85	14	62	125	27	10	62
PB20G	M33 × 2	G 1"	47	9	85	14	62	125	27	10	57
PB25G	M42 × 2	G 1 1/4"	56	9	100	18	72	138	40	13	66
PB30G	M48 × 2	G 1 1/2"	61	9	100	18	72	138	40	13	66

PB	10	*	1	60	31.5	*	*	*	*
----	----	---	---	----	------	---	---	---	---

型号 Model

通径 Size

板式: 10;20;30

管式: 8;10;15;20;25;30

Subplate mounting:10;20;30

Threaded connection:8;10;15;
20;25;30

无=板式 No code=subplate mounting

G=管式 G=Threaded connection

1=带手轮; 2=不带手轮

1=Hand wheel

2=Without hand wheel

系列号: 60系列; 6X系列 Series number:60;6X

压力等级 Pressure range (Mpa) 5;10;20;31.5

无 = 丁晴橡胶

V= 氟橡胶

No code=NBR seals

V=FPM seals

无=英制;2=公制

No code=Inch thread;

2=Metric thread

无标记 = 主阀芯硬弹簧

U = 主阀芯软弹簧

No Code=Standard

U=For min.cracking pressure

无 = 先导控制油内供内排

X = 先导控制油外供内排

Y = 先导控制油内供外排

XY = 先导控制油外供外排

No code = Internally pilot, internally drained

X = External pilot, internally drained

Y = Internally pilot, externally drained

XY = External pilot, externally drained