

Technical data

The foot brackets are proportioned to support IEC Electric motors with B5 flange without feet.

The range is available from size 71 to size 180.

Compatibility with fluids

- Mineral oils types HH-LL-HM-HR-HV-HC, to ISO 6743/4 standard
- Water based emulsions types HFAE-HFAS, to ISO 6743/4 standard
- Water glycol type HFC, to ISO 6743/4 standard: ask for anodized version

Materials

Foot bracket: pressure die-cast aluminium alloy

Temperature

From -30 °C to +80 °C

Dimensions

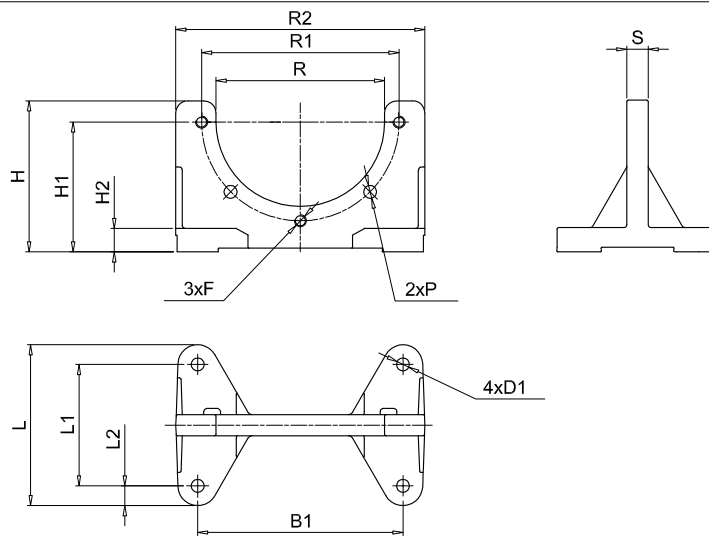

Dimensions [mm]

Foot bracket	B	B1	R2	L	L1	L2	H	H1	H2	R	R1	S	P	D1	F	Weight [kg]
PDM A 160	160	135	180	106	80	13	100	86	16	111	130	14	8.5	8.5	M8	0.45
PDM A 200	200	175	207	128	98	21	128	115	14	146	165	14	11.0	11.5	M10	0.60
PDM A 250	250	220	262	172	130	21	157	145	18	191	215	16	13.0	13.5	M12	1.20
PDM A 300	300	270	320	210	160	25	188	170	18	235	265	20	13.0	13.5	M12	1.80

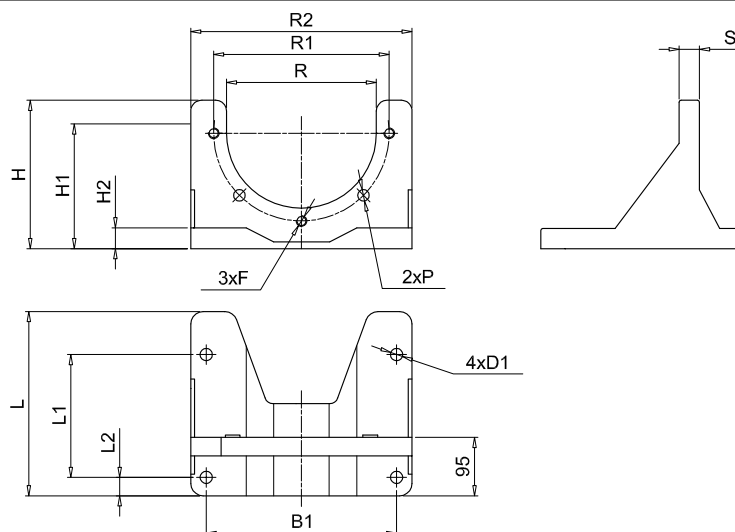

Dimensions [mm]

Foot bracket	B	B1	R2	L	L1	L2	H	H1	H2	R	R1	S	P	D1	F	Weight [kg]
PDM A 350	350	310	360	300	200	30	220	200	30	261	300	30	18	13	M16	4.80